

# Ø 190x88 mm

**San Ace 190AD 9ADTU** type

## General Specifications

- Material ..... Motor case: Aluminum (Black coating), Impeller: Plastic (Flammability: UL 94V-0)
- Expected life ..... See the table below. (L10 life: 90% survival rate for continuous operation in free air at 60°C, rated voltage) Expected life at 40°C is for reference only.
- Motor protection function ..... Locked rotor burnout protection For details, please refer to p. 580.
- Dielectric strength ..... 50/60 Hz, 1500 VAC, for 1 minute (between lead wire conductors and motor case)
- Insulation resistance ..... 10 MΩ min. at 500 VDC (between lead wire conductors and motor case)
- Sound pressure level (SPL) ..... A-weighted sound pressure level (SPL) at 1 m away from the air inlet.
- Storage temperature ..... -30 to +70°C (Non-condensing)
- Lead wire ..... 

AC power input	L: Orange	N: Gray	Ground	Yellow / Green
+10 VDC output	Red	Black	Sensor	Yellow
			Control	Brown
- Mass ..... 1600 g

## Specifications When the optional inlet nozzle (109-1073) is mounted.

The models listed below **have pulse sensors with PWM control function.**

Model no.	Rated voltage [V]	Operating voltage range [V]	Frequency [Hz]	PWM duty cycle [%]	Rated current [A]	Rated input [W]	Rated speed [min <sup>-1</sup> ]	Max. airflow [m <sup>3</sup> /min] [CFM]	Max. static pressure [Pa] [inchH <sub>2</sub> O]	SPL [dB (A)]	Operating temperature [°C]	Expected life [h]
9ADTU11P0G001	115	90 to 132	50/60	100	2.5	150	4800	16.5 583	1200 4.82	72	-25 to +60	40000/60°C (70000/40°C)
				20	0.3	10	1000	3.3 116	52 0.21	43		
9ADTU23P0G001	230	180 to 264		100	1.3	150	4800	16.5 583	1200 4.82	72		
				20	0.2	10	1000	3.3 116	52 0.21	43		

\* PWM frequency is 1 kHz. Models without ratings for 0% PWM duty cycle have zero speed at 0%. When control terminal is open, speed is the same as at 100% duty cycle.

## Airflow - Static Pressure Characteristics / PWM Duty - Speed Characteristics Example

### 9ADTU11P0G001 With pulse sensor with PWM control function

PWM duty cycle

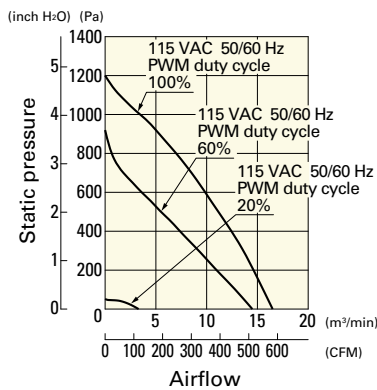

PWM duty - Speed characteristics example

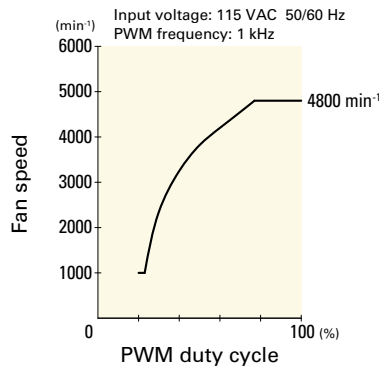

### 9ADTU23P0G001 With pulse sensor with PWM control function

PWM duty cycle

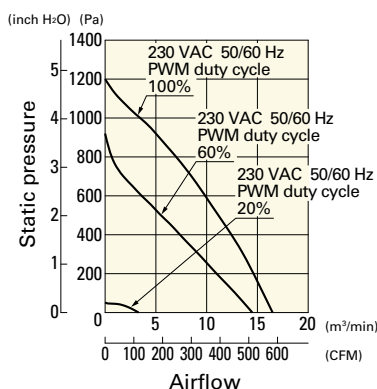

PWM duty - Speed characteristics example

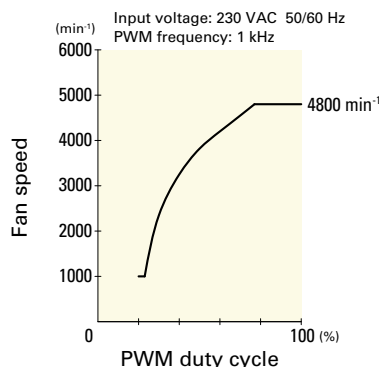

## Connection Schematic

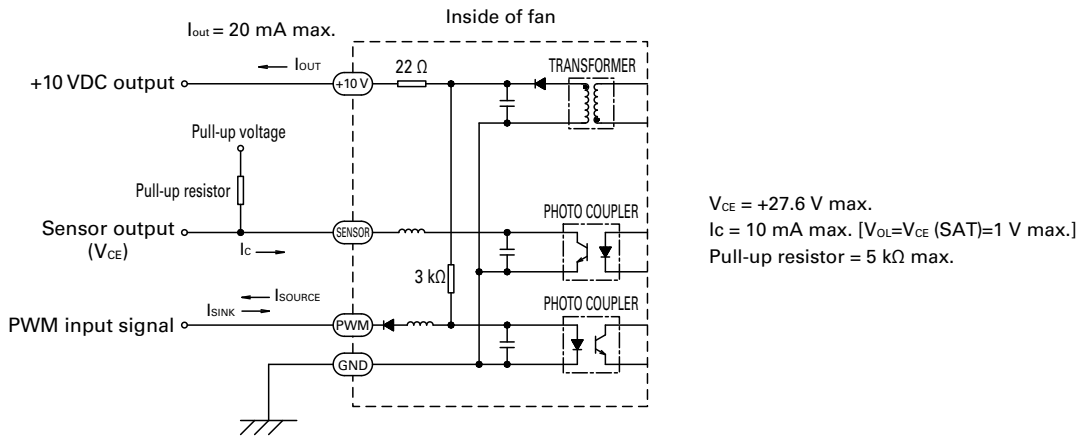

## Dimensions (unit: mm)

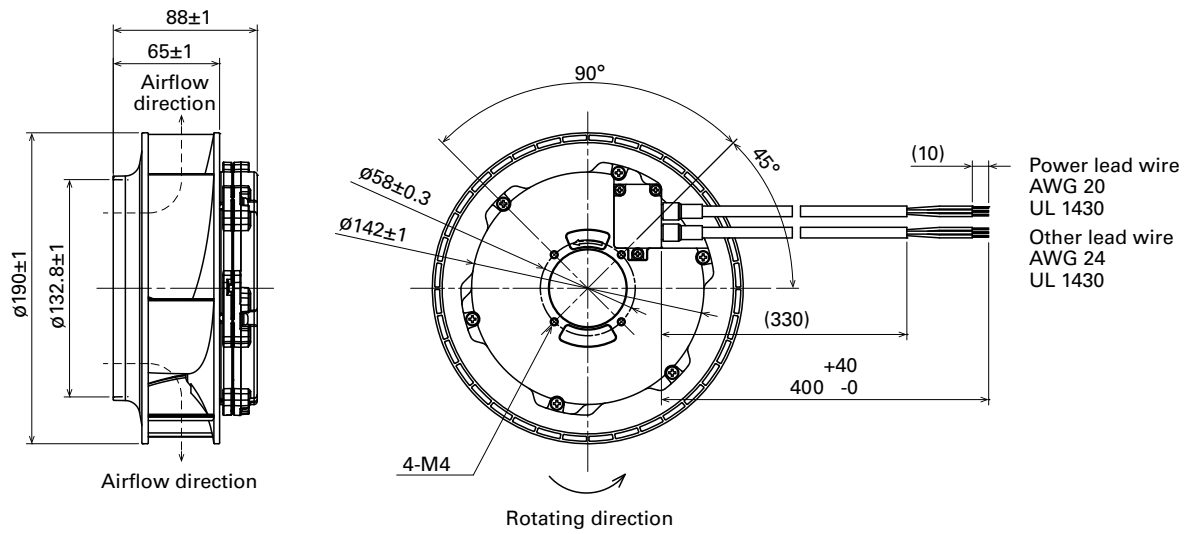

## Reference Dimensions of Mounting Holes and Vent Opening (unit: mm)

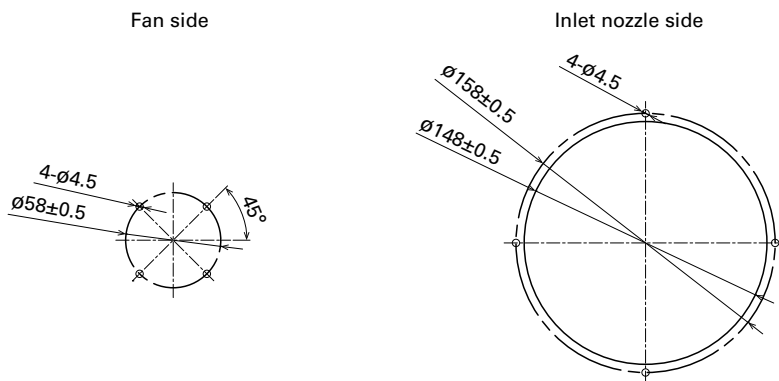

## Reference Diagram for Mounting (unit: mm)

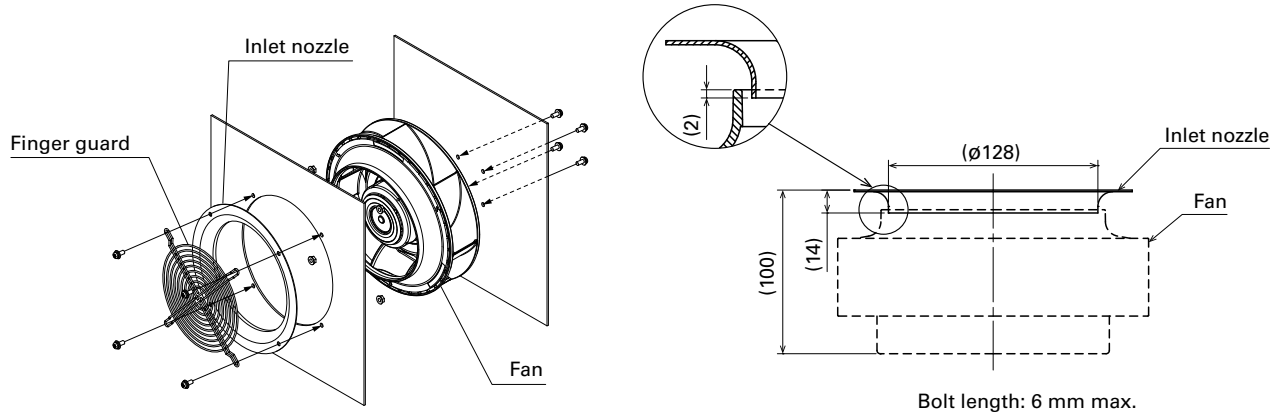

## Options

Finger guards

page: p. 565

Model no.: 109-722, 109-722H

Inlet nozzle

page: p. 569

Model no.: 109-1073, 109-1073H



# Ø 225x99 mm

San Ace 225AD 9ADTS type

## General Specifications

- Material ..... Motor case: Aluminum (Black coating), Impeller: Plastic (Flammability: UL 94V-0)
- Expected life ..... See the table below. (L10 life: 90% survival rate for continuous operation in free air at 60°C, rated voltage) Expected life at 40°C is for reference only.
- Motor protection function ..... Locked rotor burnout protection For details, please refer to p. 580.
- Dielectric strength ..... 50/60 Hz, 1500 VAC, for 1 minute (between lead wire conductors and motor case)
- Insulation resistance ..... 10 MΩ min. at 500 VDC (between lead wire conductors and motor case)
- Sound pressure level (SPL) ..... A-weighted sound pressure level (SPL) at 1 m away from the air inlet.
- Storage temperature ..... -30 to +70°C (Non-condensing)
- Lead wire ..... 

AC power input	L: Orange	N: Gray	Ground	Yellow / Green
+10 VDC output	Red	Black	Sensor	Yellow
			Control	Brown
- Mass ..... 1800 g

## Specifications When the optional inlet nozzle (109-1134) is mounted.

The models listed below **have pulse sensors with PWM control function.**

Model no.	Rated voltage [V]	Operating voltage range [V]	Frequency [Hz]	PWM duty cycle [%]	Rated current [A]	Rated input [W]	Rated speed [min <sup>-1</sup> ]	Max. airflow [m <sup>3</sup> /min] [CFM]	Max. static pressure [Pa] [inchH <sub>2</sub> O]	SPL [dB (A)]	Operating temperature [°C]	Expected life [h]			
9ADTS11P0G001	115	90 to 132	50/60	100	2.23	155	3200	23.0 812	815 3.27	74	-20 to +60	40000/60°C (70000/40°C)			
				20	0.3	10	1000	7.1 252	80 0.32	50					
9ADTS11P0F001				100	1.11	70	2450	17.6 621	480 1.93	68					
				20	0.3	10	1000	7.1 252	80 0.32	50					
9ADTS23P0G001				230	180 to 264	50/60	100	1.17	155	3200			23.0 812	815 3.27	74
							20	0.2	10	1000			7.1 252	80 0.32	50
9ADTS23P0F001	100	0.64	70				2450	17.6 621	480 1.93	68					
	20	0.2	10				1000	7.1 252	80 0.32	50					

\* PWM frequency is 1 kHz. Models without ratings for 0% PWM duty cycle have zero speed at 0%. When control terminal is open, speed is the same as at 100% duty cycle.

## Airflow - Static Pressure Characteristics / PWM Duty - Speed Characteristics Example

**9ADTS11P0G001** With pulse sensor with PWM control function

PWM duty cycle

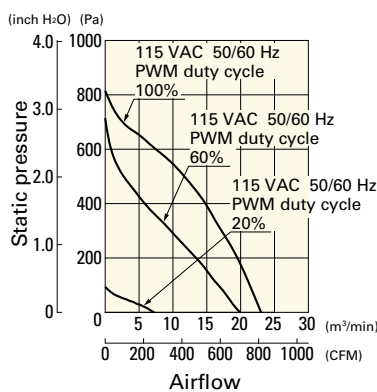

PWM duty - Speed characteristics example

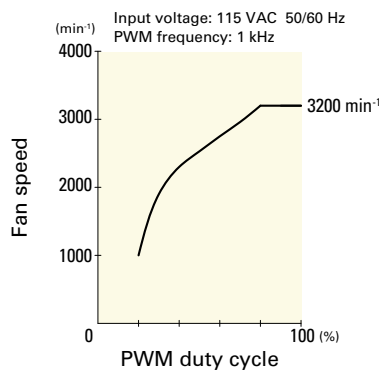

ACDC Fan Ø225 mm

## Airflow - Static Pressure Characteristics / PWM Duty - Speed Characteristics Example

**9ADTS11P0F001** With pulse sensor with PWM control function

PWM duty cycle

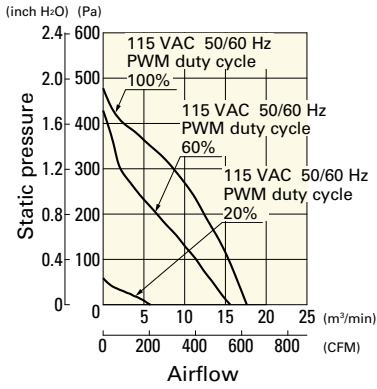

PWM duty - Speed characteristics example

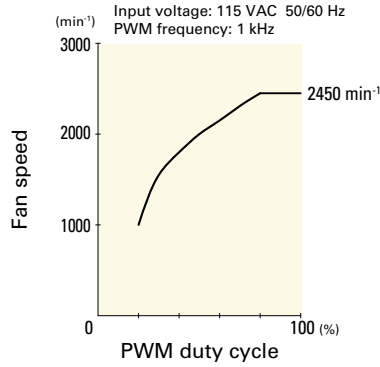

**9ADTS23P0G001** With pulse sensor with PWM control function

PWM duty cycle

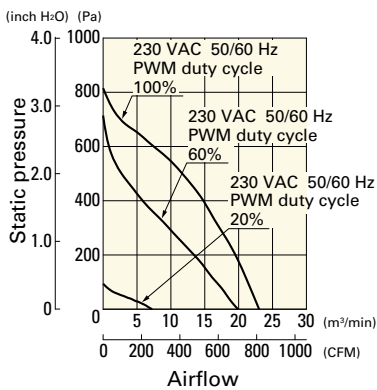

PWM duty - Speed characteristics example

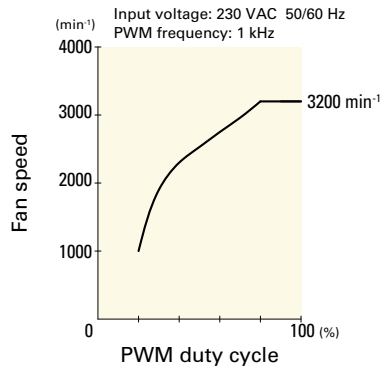

**9ADTS23P0F001** With pulse sensor with PWM control function

PWM duty cycle

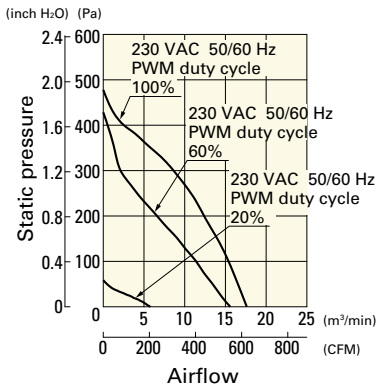

PWM duty - Speed characteristics example

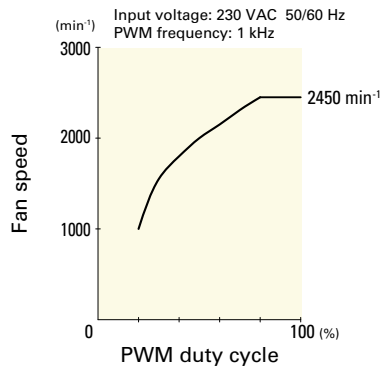

## Connection Schematic

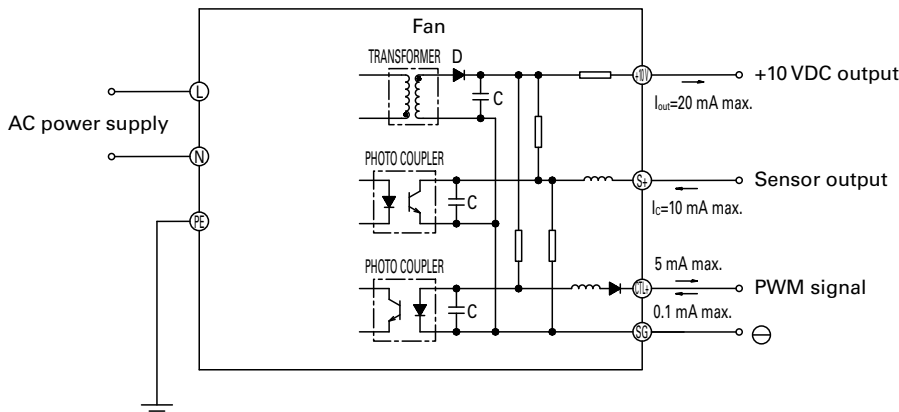

ACDC  
ACDC Fan φ225 mm

## Dimensions (unit: mm)

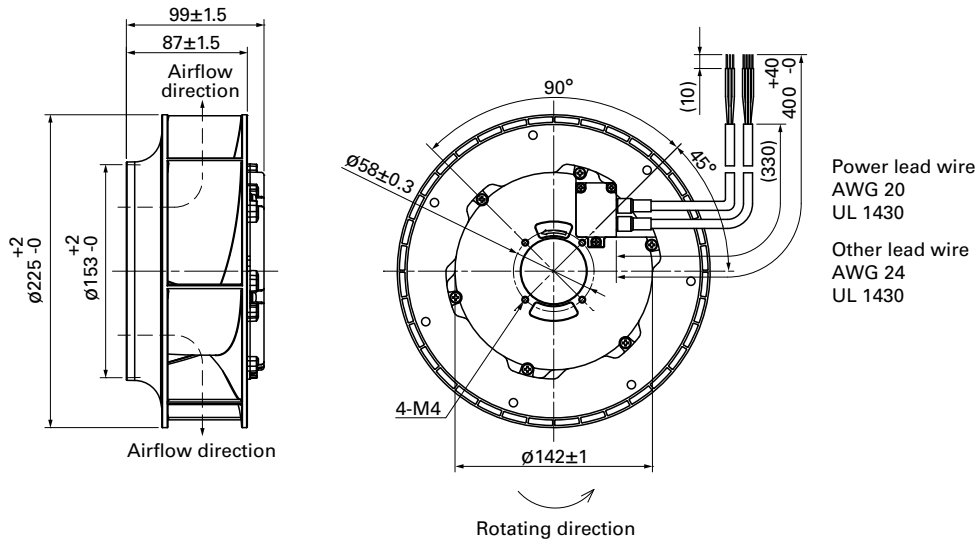

## Reference Dimensions of Mounting Holes and Vent Opening (unit: mm)

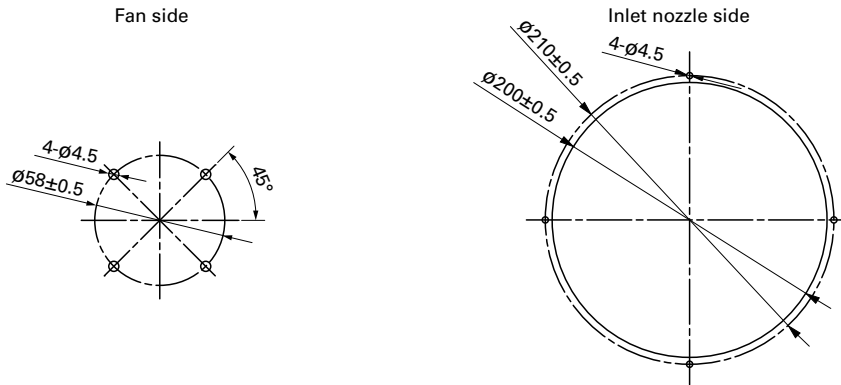

## Reference Diagram for Mounting (unit: mm)

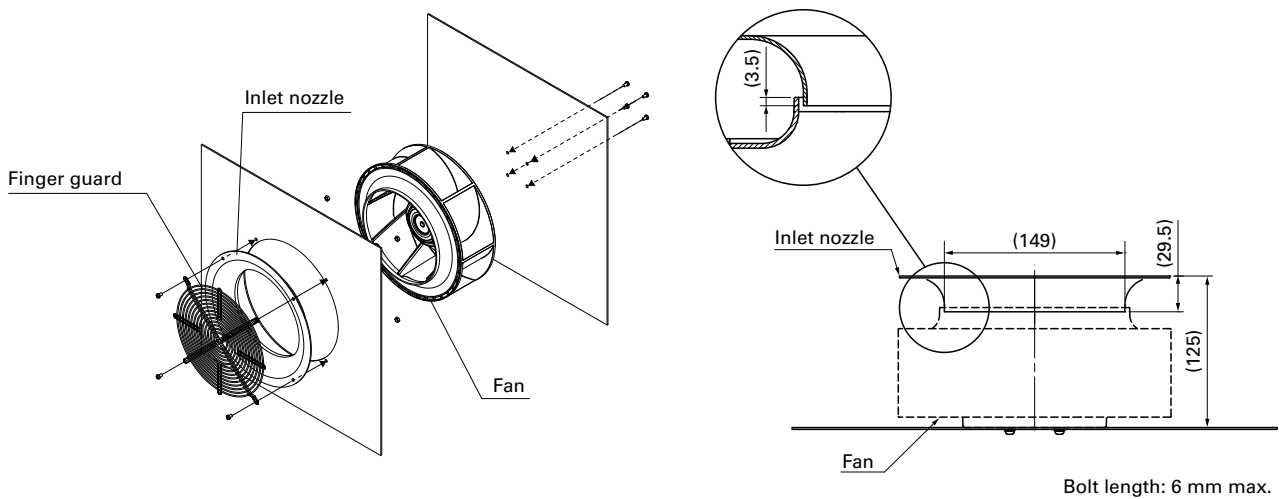

## Options

Finger guards

page: p. 567

Model no.: 109-1137, 109-1137H

Inlet nozzle

page: p. 569

Model no.: 109-1134, 109-1134H

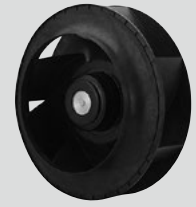

# ∅250×99 mm

San Ace 250AD 9ADTV type

## General Specifications

- Material ..... Motor case: Aluminum (Black coating), Impeller: Plastic (Flammability: UL 94V-0)
- Expected life ..... See the table below. (L10 life: 90% survival rate for continuous operation in free air at 60°C, rated voltage) Expected life at 40°C is for reference only.
- Motor protection function ..... Locked rotor burnout protection For details, please refer to p. 580.
- Dielectric strength ..... 50/60 Hz, 1500 VAC, for 1 minute (between lead wire conductors and motor case)
- Insulation resistance ..... 10 MΩ min. at 500 VDC (between lead wire conductors and motor case)
- Sound pressure level (SPL) ..... A-weighted sound pressure level (SPL) at 1 m away from the air inlet.
- Storage temperature ..... -30 to +70°C (Non-condensing)
- Lead wire ..... 

AC power input	L: Orange	N: Gray	Ground	Yellow / Green
+10 VDC output	Red	Black	Sensor	Yellow
			Control	Brown
- Mass ..... 1920 g

## Specifications When the optional inlet nozzle (109-1151) is mounted.

The models listed below **have pulse sensors with PWM control function.**

Model no.	Rated voltage [V]	Operating voltage range [V]	Frequency [Hz]	PWM duty cycle [%]	Rated current [A]	Rated input [W]	Rated speed [min <sup>-1</sup> ]	Max. airflow [m <sup>3</sup> /min] [CFM]	Max. static pressure [Pa] [inchH <sub>2</sub> O]	SPL [dB (A)]	Operating temperature [°C]	Expected life [h]
9ADTV11P0G001	115	90 to 132	50/60	100	2.3	140	2700	26.5 936	650 2.61	71	-25 to +60	40000/60°C (70000/40°C)
				20	0.3	10	1000	9.6 339	88 0.35	57		
9ADTV23P0G001	230	180 to 264		100	1.2	140	2700	26.5 936	650 2.61	71		
				20	0.2	10	1000	9.6 339	88 0.35	57		

\* PWM frequency is 1 kHz. Models without ratings for 0% PWM duty cycle have zero speed at 0%. When control terminal is open, speed is the same as at 100% duty cycle.

## Airflow - Static Pressure Characteristics / PWM Duty - Speed Characteristics Example

### 9ADTV11P0G001 With pulse sensor with PWM control function

PWM duty cycle

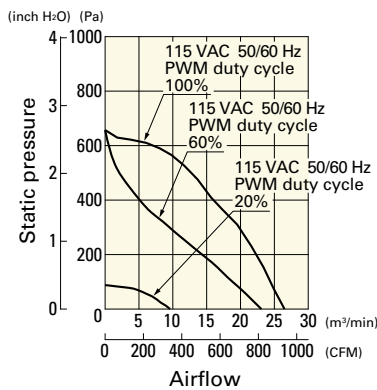

PWM duty - Speed characteristics example

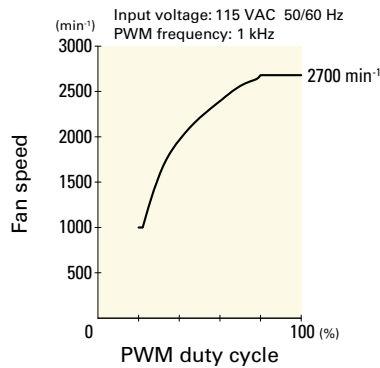

### 9ADTV23P0G001 With pulse sensor with PWM control function

PWM duty cycle

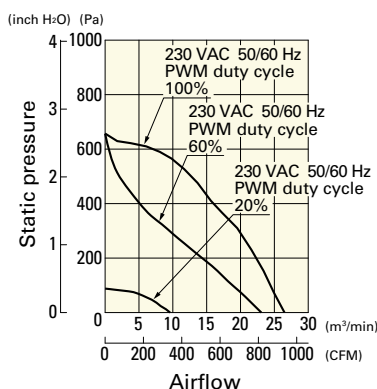

PWM duty - Speed characteristics example

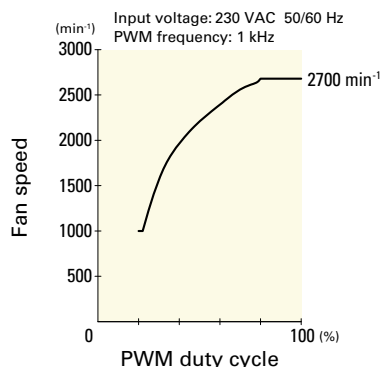

## Connection Schematic

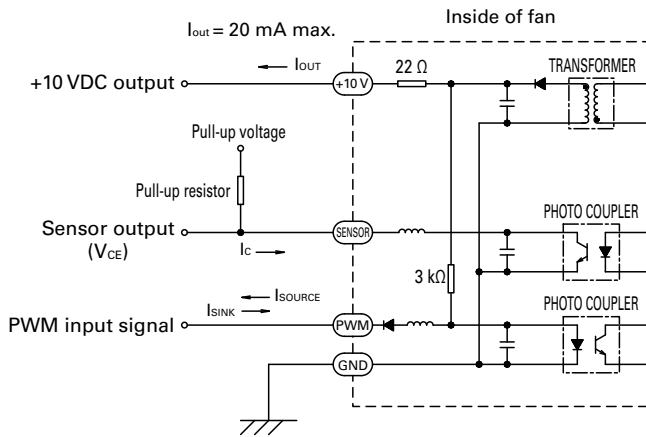

$V_{CE} = +27.6 \text{ V max.}$   
 $I_C = 10 \text{ mA max. [V}_{OL}=V_{CE}(\text{SAT})=1 \text{ V max.}]$   
 Pull-up resistor =  $5 \text{ k}\Omega \text{ max.}$

## Dimensions (unit: mm)

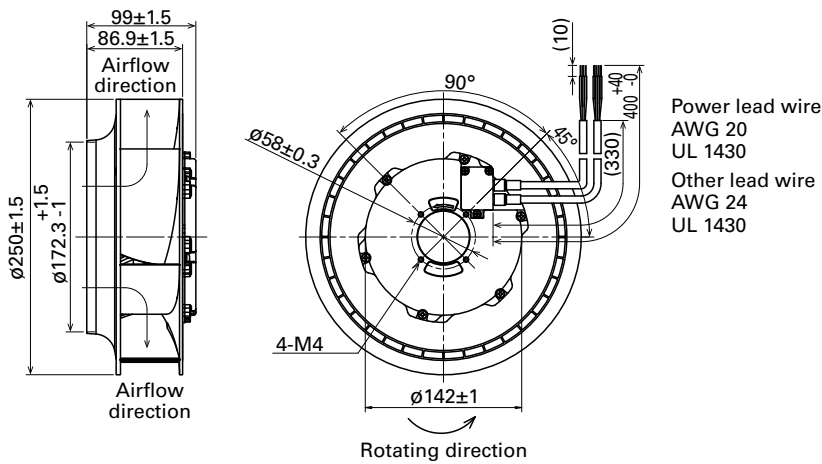

## Reference Dimensions of Mounting Holes and Vent Opening (unit: mm)

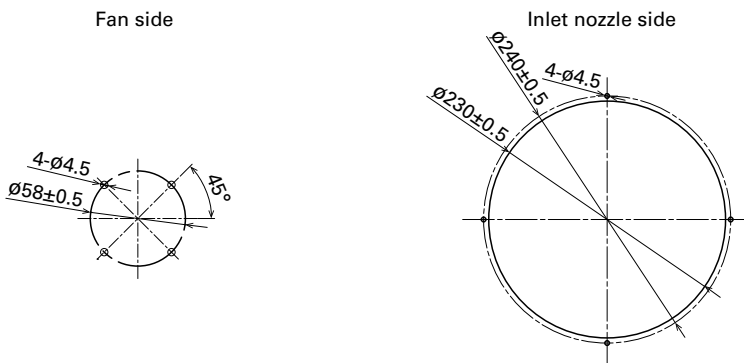

## Reference Diagram for Mounting (unit: mm)

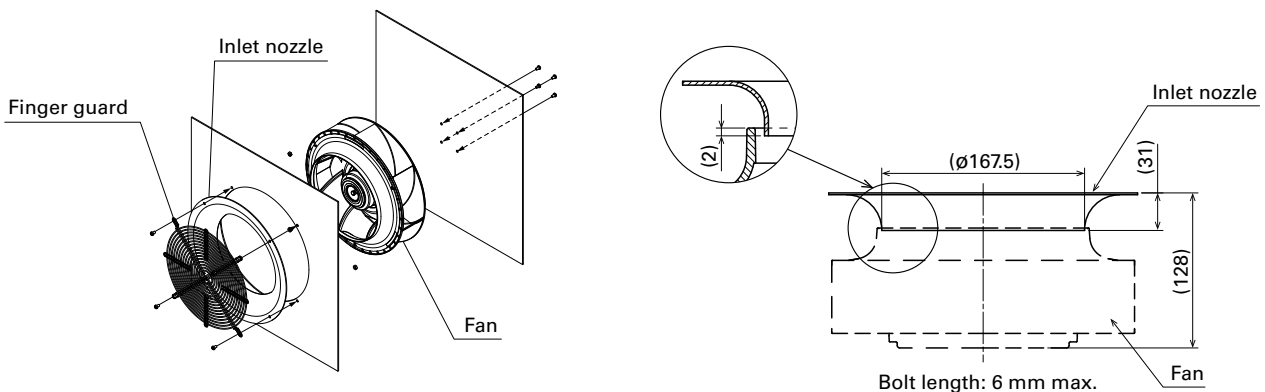



## Options

---

Finger guards

page: p. 568

Model no.: 109-1152,109-1152H

Inlet nozzle

page: p. 569

Model no.: 109-1151,109-1151H

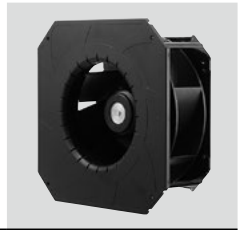

# 270x270x119 mm

San Ace 225AD 9ADB1TS type

## General Specifications

- Material ..... Motor case: Aluminum (Black coating), Impeller: Plastic (Flammability: UL 94V-0)  
Bracket: Aluminum (Black coating), Plastic (Flammability: UL94V-0)
- Expected life ..... See the table below. (L10 life: 90% survival rate for continuous operation in free air at 60°C, rated voltage)  
Expected life at 40°C is for reference only.
- Motor protection function ..... Locked rotor burnout protection  
For details, please refer to p. 580.
- Dielectric strength ..... 50/60 Hz, 1500 VAC, for 1 minute (between lead wire conductors and bracket)
- Insulation resistance ..... 10 MΩ min. at 500 VDC (between lead wire conductors and bracket)
- Sound pressure level (SPL) ..... A-weighted sound pressure level (SPL) at 1 m away from the air inlet.
- Storage temperature ..... -30 to +70°C (Non-condensing)
- Lead wire ..... 

AC power input	L: Orange	N: Gray	Ground	Yellow / Green
+10 VDC output	Red	Black	Sensor	Yellow
			Control	Brown
- Mass ..... 2500 g

## Specifications

The models listed below **have pulse sensors with PWM control function.**

Model no.	Rated voltage [V]	Operating voltage range [V]	Frequency [Hz]	PWM duty cycle [%]	Rated current [A]	Rated input [W]	Rated speed [min <sup>-1</sup> ]	Max. airflow [m <sup>3</sup> /min] [CFM]	Max. static pressure [Pa] [inchH <sub>2</sub> O]	SPL [dB (A)]	Operating temperature [°C]	Expected life [h]
9ADB1TS11P0G001	115	90 to 132	50/60	100	2.23	155	3200	23.0 812	815 3.27	74	-20 to +60	40000/60°C (70000/40°C)
				20	0.3	10	1000	7.1 252	80 0.32	50		
9ADB1TS11P0F001	115	90 to 132	50/60	100	1.11	70	2450	17.6 621	480 1.93	68		
				20	0.3	10	1000	7.1 252	80 0.32	50		
9ADB1TS23P0G001	230	180 to 264	50/60	100	1.17	155	3200	23.0 812	815 3.27	74		
				20	0.2	10	1000	7.1 252	80 0.32	50		
9ADB1TS23P0F001	230	180 to 264	50/60	100	0.64	70	2450	17.6 621	480 1.93	68		
				20	0.2	10	1000	7.1 252	80 0.32	50		

\* PWM frequency is 1 kHz. Models without ratings for 0% PWM duty cycle have zero speed at 0%. When control terminal is open, speed is the same as at 100% duty cycle.

## Airflow - Static Pressure Characteristics / PWM Duty - Speed Characteristics Example

**9ADB1TS11P0G001** With pulse sensor with PWM control function

PWM duty cycle

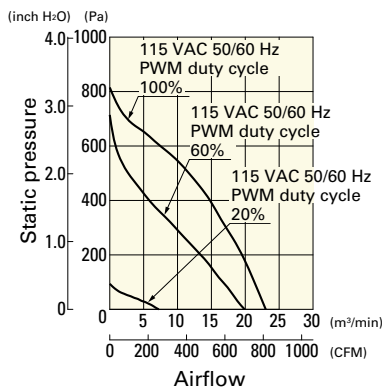

PWM duty - Speed characteristics example

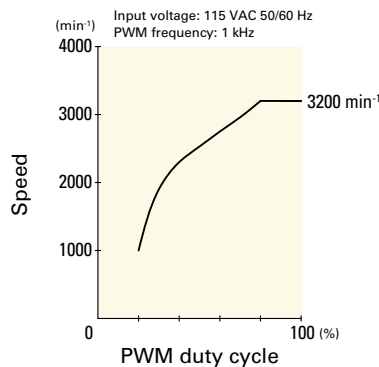

## Airflow - Static Pressure Characteristics / PWM Duty - Speed Characteristics Example

**9ADB1TS11P0F001** With pulse sensor with PWM control function

PWM duty cycle

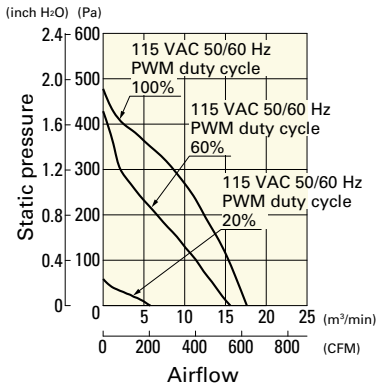

PWM duty - Speed characteristics example

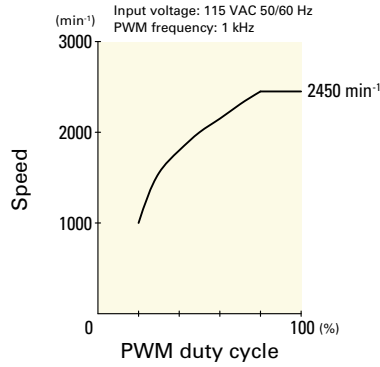

**9ADB1TS23P0G001** With pulse sensor with PWM control function

PWM duty cycle

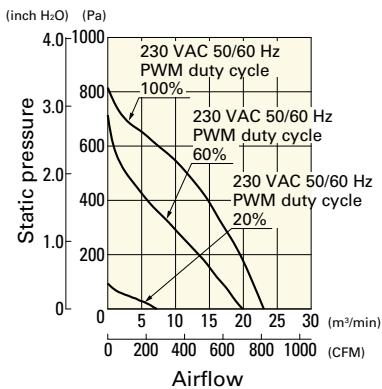

PWM duty - Speed characteristics example

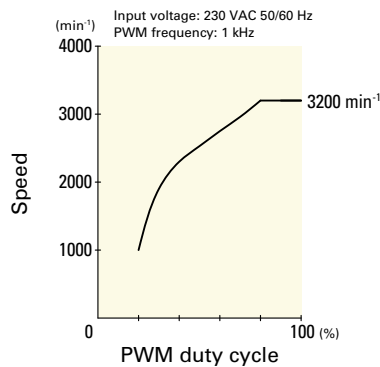

**9ADB1TS23P0F001** With pulse sensor with PWM control function

PWM duty cycle

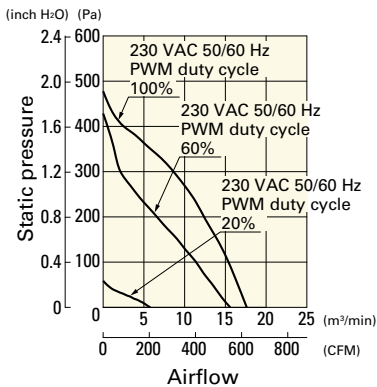

PWM duty - Speed characteristics example

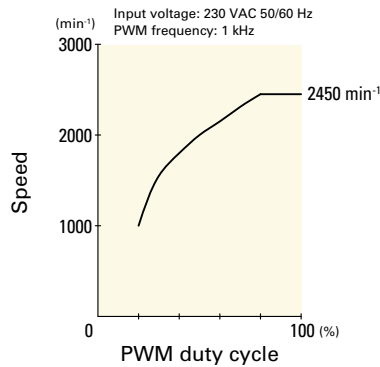

## Connection Schematic

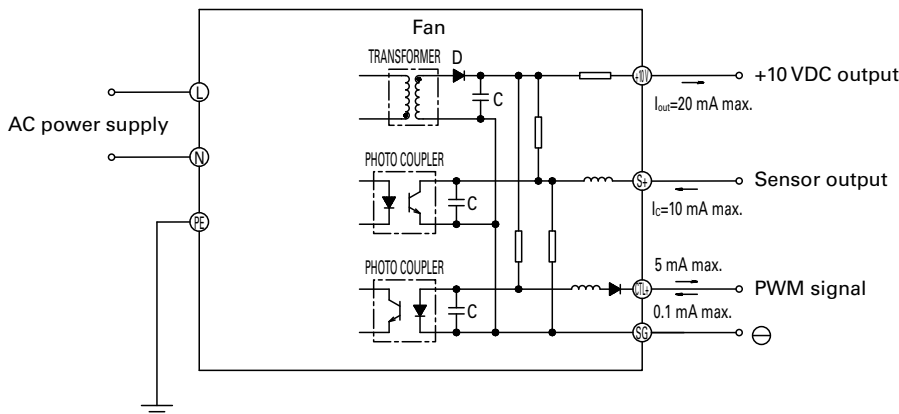

## Dimensions (unit: mm)

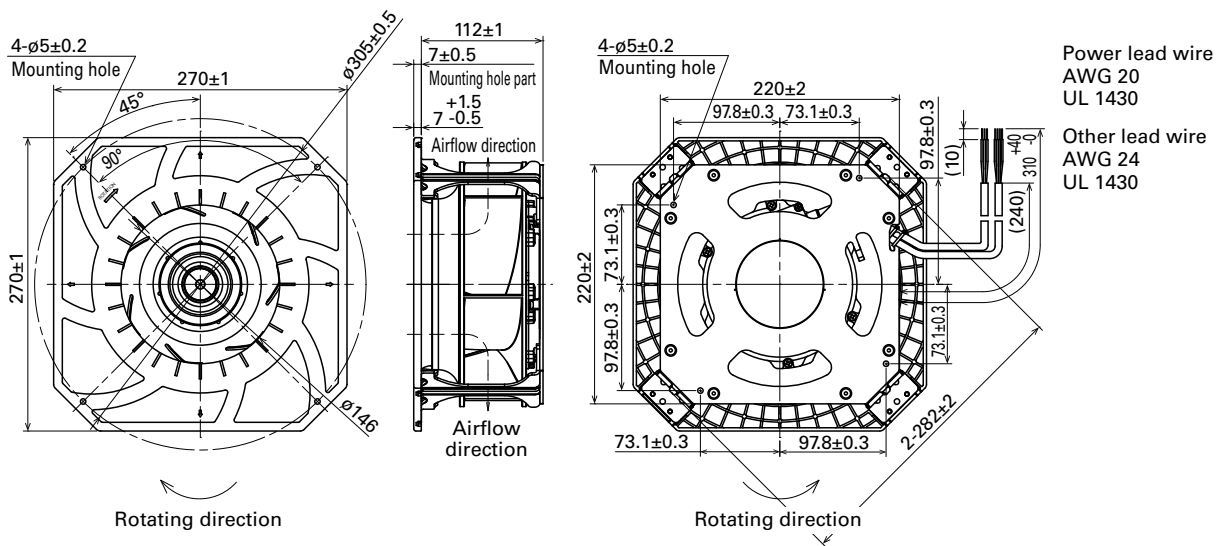

## Reference Dimensions of Mounting Holes and Vent Opening (unit: mm)

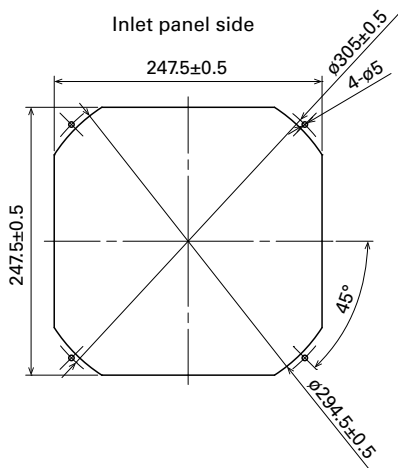

## Reference Diagram for Mounting

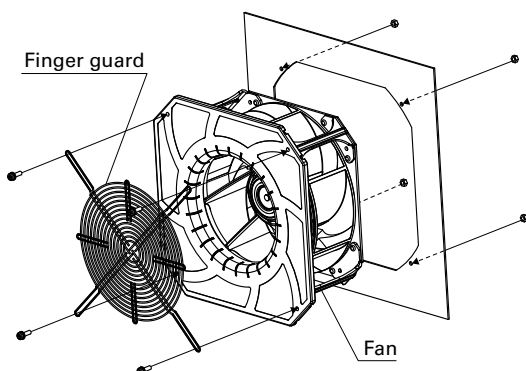

## Options

Finger guards

page: p. 568

Model no.: 109-1146, 109-1146H