



80×80×42 mm

San Ace 80

General Specifications

- Material Frame: Aluminum (Black coating), Impeller: Plastic (Flammability: UL 94V-1)
- Expected life See the table below. (L10 life: 90% survival rate for continuous operation in free air at 60°C, rated voltage) Expected life at 40°C is for reference only.
- Motor structure Shaded coil motor
- Motor protection function Locked rotor burnout protection, Reverse polarity protection
For details, please refer to p. 580.
- Dielectric strength 50/60 Hz, 1500 VAC, for 1 minute (between input terminal and frame)
- Insulation resistance 10 MΩ min. at 500 VDC
- Sound pressure level (SPL) A-weighted sound pressure level (SPL) at 1 m away from the air inlet.
- Operating voltage range Voltage of each model ±10%
- Storage temperature -30 to +70°C (Non-condensing)
- Mass 410 g

Specifications

Model no.	Rated voltage [V]	Frequency [Hz]	Input [W]	Current [A]	Locked rotor current [A]	Rated speed [min ⁻¹]	Max. airflow [m ³ /min] [CFM]	Max. static pressure [Pa] [inchH ₂ O]	SPL [dB (A)]	Operating temperature [°C]	Expected life [h]
109-040UL	100	50/60	10/9	0.13/0.11	0.16/0.14	2650/3100	0.85/1.0 30.0/35.3	24.5/35.3 0.098/0.142	40/44	-30 to +60	25000/60°C (56000/40°C)
109-043UL	115			0.11/0.1	0.14/0.12						
109-041UL	200			0.07/0.06	0.08/0.07						
109-044UL	230			0.06/0.05	0.07/0.06						
109-047UL*	100			0.05/0.05	0.05/0.05						
109-033UL*	115	4/3.5	0.04/0.04	0.04/0.04	1500/1500	0.43/0.43 15.2/15.2	8.8/ 8.8 0.035/0.035	24/24			

* These are low-speed models.

Note: These are Short Lead Time Service applicable models. Contact your point of sale for stock availability. For more information on the service, see p. 630.

AC Fan 80 mm sq.

Set Models

Fan, finger guard, plug cord, screws, etc. can be purchased in one package. For details, please refer to p. 631.

Order no.	Set items					
	Fan	Voltage	Low-speed sensor	Plug cord*	Finger guards	Mounting screws
ST1-109-040UL	109-040UL	100 V		489-008-L10	109-049E	M4×55 mm (4 screws)
ST1-109-043UL	109-043UL	115 V		489-008-L10	109-049E	
ST1-109-041UL	109-041UL	200 V		489-008-L10	109-049E	
ST1-109-044UL	109-044UL	230 V		489-008-L10	109-049E	
ST1-109-047UL	109-047UL	100 V		489-008-L10	109-049E	
ST1-109-033UL	109-033UL	115 V		489-008-L10	109-049E	

* PSE compatible.

Airflow - Static Pressure Characteristics

109-040UL, 109-043UL, 109-041UL, 109-044UL

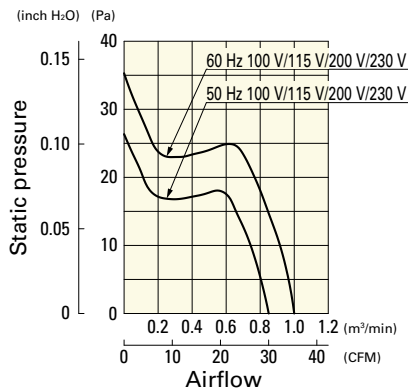

109-047UL, 109-033UL

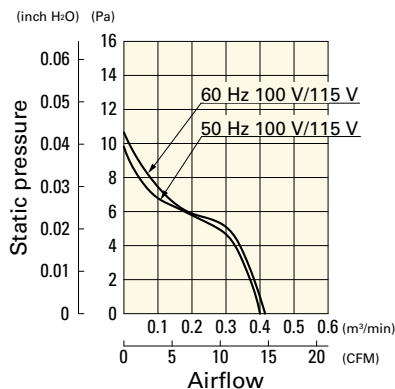

Dimensions (unit: mm)

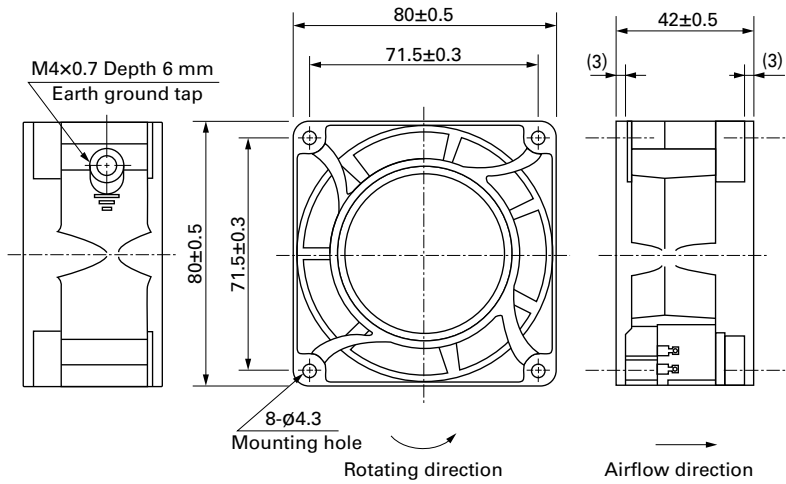

Reference Dimensions of Mounting Holes and Vent Opening (unit: mm)

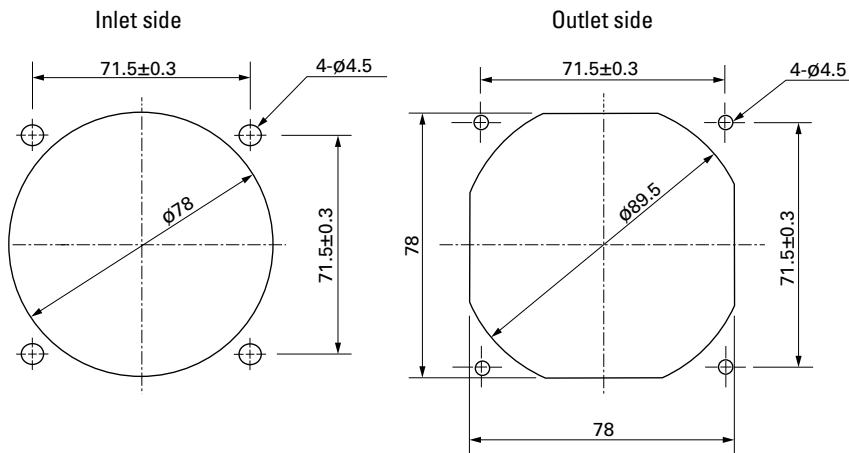

Connection Schematic

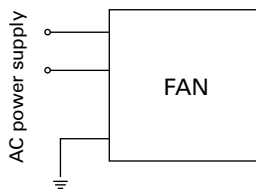

Options

Finger guards

page: p. 564

Model no.: 109-049E, 109-049H, 109-049C

Resin finger guards

page: p. 571

Model no.: 109-1002G

Resin filter kits

page: p. 572

Model no.: 109-1002F13 (13PPI), 109-1002F20 (20PPI),
109-1002F30 (30PPI), 109-1002F40 (40PPI)

Plug cord

pp. 574 to 575

Model no.: 489-008-L10, 489-008-L21, 489-008-L35