



42 mm sq.

1.8°/step **Thin-profile** **RoHS**
Bipolar, lead type



Custom options

- Hollow shaft Custom shaft
- Encoder

Note: Customization feasibility depends on the model number and quantity. Contact us for details.

Bipolar, lead type Radial load: 10 N

Model no.		Holding torque at 2-phase excitation	Rated current	Winding resistance	Winding inductance	Rotor inertia	Mass	Motor length (L)
Single shaft	Dual shaft	N·m or more	A/phase	Ω/phase	mH/phase	×10 ⁻⁴ kg·m ²	kg	mm
SS2421-5041	SS2421-5011	0.083	1	3.5	1.2	0.015	0.07	11.6
SS2422-5041	SS2422-5011	0.186	1	5.4	2.9	0.028	0.14	18.6

Bipolar, lead type **Heavy duty** Radial load: 25 N

Model no.		Holding torque at 2-phase excitation	Rated current	Winding resistance	Winding inductance	Rotor inertia	Mass	Motor length (L)
Single shaft	Dual shaft	N·m or more	A/phase	Ω/phase	mH/phase	×10 ⁻⁴ kg·m ²	kg	mm
SS2421-50400	SS2421-50100	0.083	1	3.5	1.2	0.015	0.09	14.5
SS2422-50400	SS2422-50100	0.186	1	5.4	2.9	0.028	0.16	21.5

Characteristics

SS2421-5041
SS2421-5011

SS2421-50400
SS2421-50100

Constant current circuit
Input voltage: 24 VDC
Winding current: 1 A/phase
At 2-phase excitation (full step)
Pull-out torque:
 $J_L = 0.33 \times 10^{-4} \text{kg}\cdot\text{m}^2$
(with rubber coupling used)
 f_s : Maximum starting pulse rate with no load

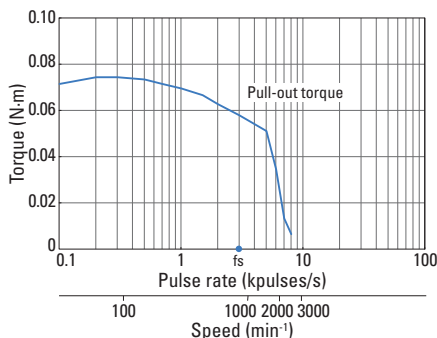

SS2422-5041
SS2422-5011

SS2422-50400
SS2422-50100

Constant current circuit
Input voltage: 24 VDC
Winding current: 1 A/phase
At 2-phase excitation (full step)
Pull-out torque:
 $J_L = 0.33 \times 10^{-4} \text{kg}\cdot\text{m}^2$
(with rubber coupling used)
 f_s : Maximum starting pulse rate with no load

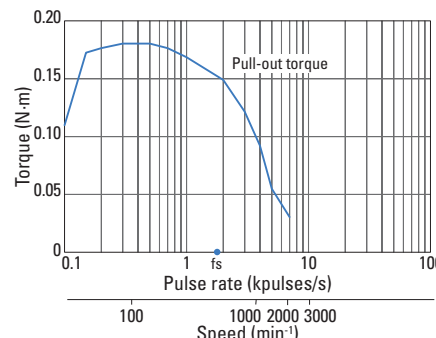

Dimensions (Unit: mm)

Model no.: SS242□-50□□

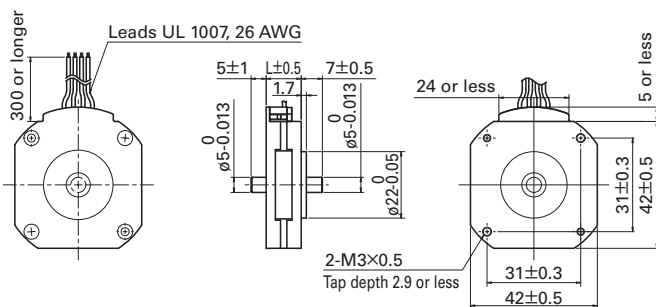

Model no.: SS242□-50□00

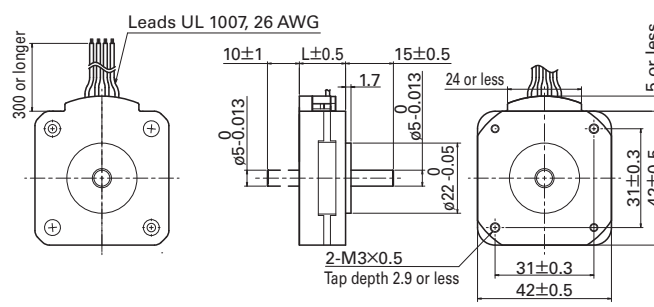

Internal winding

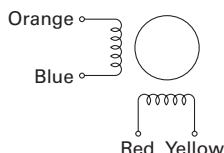

Compatible drivers

Model no.: BS1D200P10 (DC input)

Operating current selection switch setting: A

Note: The characteristics shown above are calculated using our experimental circuit.