

40x40x28 mm



San Ace 40 9GE type Low Vibration Fan **us**

General Specifications

- Material Frame: Aluminum, Impeller: Plastic (Flammability: UL 94V-0)
- Expected life See the table below. (L10 life: 90% survival rate for continuous operation in free air at 60°C, rated voltage)
Expected life at 40°C is for reference only.
- Motor protection function Locked rotor burnout protection, Reverse polarity protection
For details, please refer to p. 580.
- Dielectric strength 50/60 Hz, 500 VAC, for 1 minute (between lead wire conductors and frame)
- Insulation resistance 10 MΩ min. at 500 VDC (between lead wire conductors and frame)
- Sound pressure level (SPL) A-weighted sound pressure level (SPL) at 1 m away from the air inlet.
- Storage temperature -30 to +70°C (Non-condensing)
- Lead wire ⊕Red ⊖Black Sensor Yellow Control Brown
- Mass 55 g

Specifications

The models listed below **have pulse sensors with PWM control function.**

Model no.	Rated voltage [V]	Operating voltage range [V]	PWM duty cycle [%]	Rated current [A]	Rated input [W]	Rated speed [min ⁻¹]	Max. airflow [m ³ /min] [CFM]	Max. static pressure [Pa] [inchH ₂ O]	SPL [dB (A)]	Operating temperature [°C]	Expected life [h]
9GE0412P3K03	12	10.8 to 13.2	100	0.84	10.08	16500	0.76 26.8	415 1.666	58	-20 to +60	40000/60°C (70000/40°C)
			0	0.07	0.84	3000	0.13 4.6	13 0.052	17		
9GE0412P3J03			100	0.65	7.8	15000	0.69 24.4	343.0 1.378	56		
			0	0.05	0.6	2650	0.12 4.2	10.7 0.042	14		
9GE0412P3G03			100	0.47	5.64	13000	0.6 21.2	260 1.044	52		
			0	0.05	0.6	2400	0.11 3.9	8.2 0.033	13		

* PWM frequency is 25 kHz. Models without ratings for 0% PWM duty cycle have zero speed at 0%. When control terminal is open, speed is the same as at 100% duty cycle.

Note: Sensor and control options are available for selection. Refer to the table on p. 610.

Airflow - Static Pressure Characteristics / PWM Duty - Speed Characteristics Example

9GE0412P3K03 With pulse sensor with PWM control function

PWM duty cycle

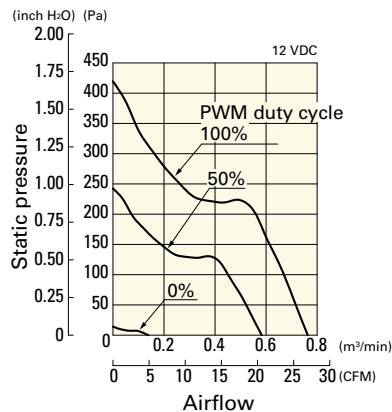

Operating voltage range

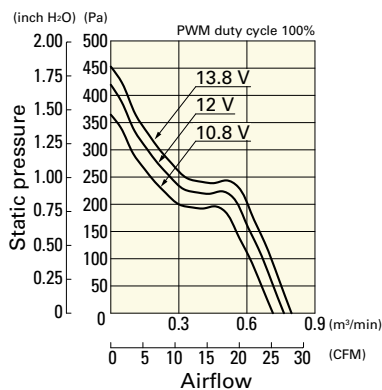

PWM duty - Speed characteristics example

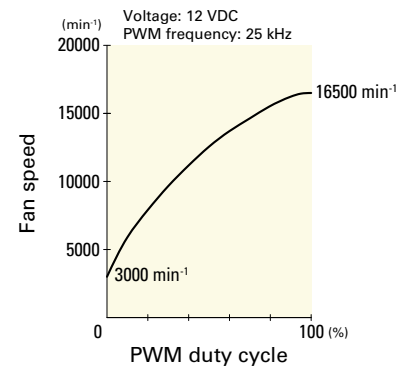

Airflow - Static Pressure Characteristics / PWM Duty - Speed Characteristics Example

9GE0412P3J03 With pulse sensor with PWM control function

PWM duty cycle

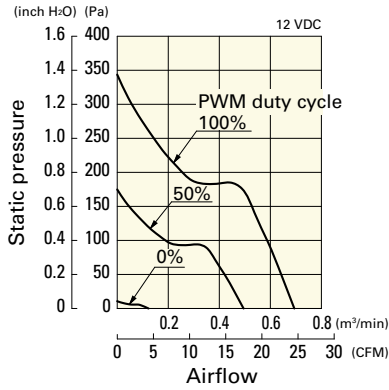

Operating voltage range

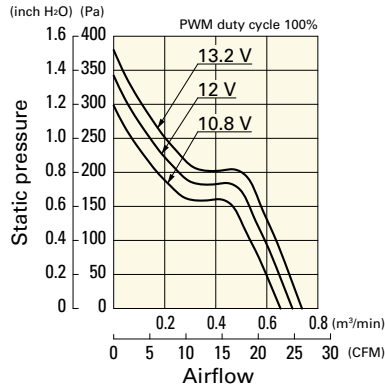

PWM duty - Speed characteristics example

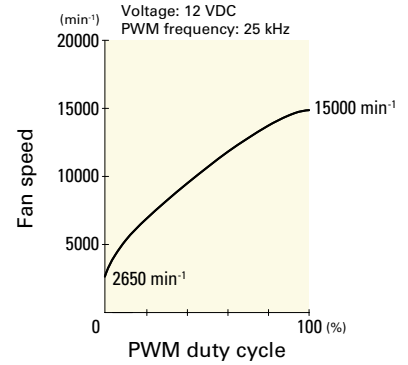

9GE0412P3G03 With pulse sensor with PWM control function

PWM duty cycle

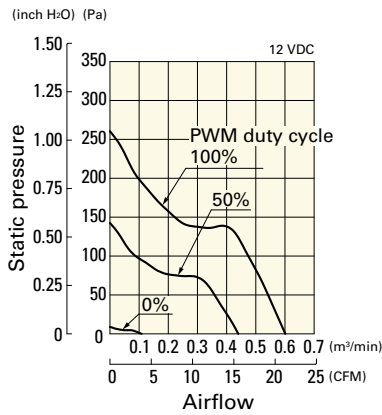

Operating voltage range

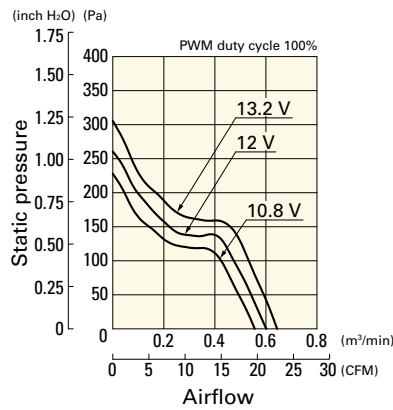

PWM duty - Speed characteristics example

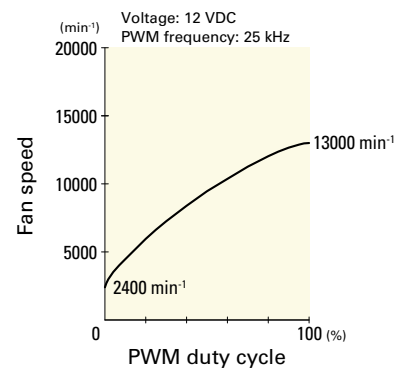

Dimensions (unit: mm)

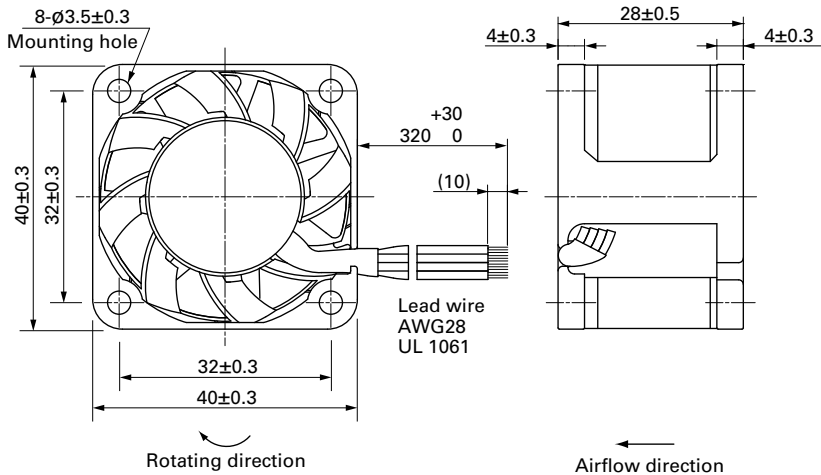

Reference Dimensions of Mounting Holes and Vent Opening (unit: mm)

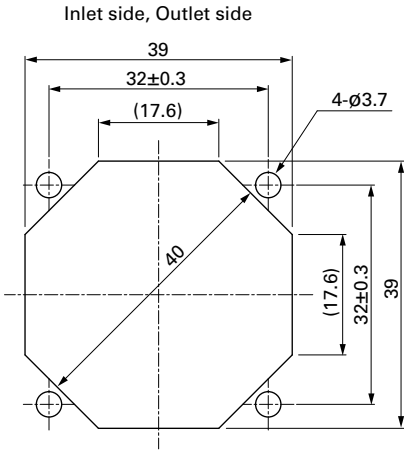

Options

Finger guards

page: p. 564

Model no.: 109-059, 109-059H