



Ø **225x99** mm

San Ace 225AD 9ADW1TS type   

General Specifications

- Material Motor case: Aluminum (Black coating), Impeller: Plastic (Flammability: UL 94V-0)
- Expected life See the table below. (L10 life: 90% survival rate for continuous operation in indoor free air at 60°C, rated voltage) Expected life at 40°C is for reference only.
- Motor protection function Locked rotor burnout protection For details, please refer to p. 580.
- Dielectric strength 50/60 Hz, 1500 VAC, for 1 minute (between lead wire conductors and motor case)
- Insulation resistance 10 MΩ min. at 500 VDC (between lead wire conductors and motor case)
- Sound pressure level (SPL) A-weighted sound pressure level (SPL) at 1 m away from the air inlet.
- Storage temperature -30 to +70°C (Non-condensing)
- Lead wire

| | | | | |
|----------------|-----------|---------|---------|----------------|
| AC power input | L: Orange | N: Gray | Ground | Yellow / Green |
| +10 VDC output | Red | Black | Sensor | Yellow |
| | | | Control | Brown |
- Mass 1900 g
- Ingress protection IP56

Specifications When the optional inlet nozzle (109-1134H) is mounted.

The models listed below **have pulse sensors with PWM control function.**

| Model no. | Rated voltage [V] | Operating voltage range [V] | Frequency [Hz] | PWM duty cycle [%] | Rated current [A] | Rated input [W] | Rated speed [min ⁻¹] | Max. airflow [m ³ /min] [CFM] | Max. static pressure [Pa] [inchH ₂ O] | SPL [dB (A)] | Operating temperature [°C] | Expected life [h] |
|-----------------|-------------------|-----------------------------|----------------|--------------------|-------------------|-----------------|----------------------------------|--|--|--------------|----------------------------|-------------------------|
| 9ADW1TS11P0H001 | 115 | 90 to 132 | 50/60 | 100 | 2.06 | 140 | 3100 | 22.3 787 | 760 3.05 | 73 | -20 to +60 | 40000/60°C (70000/40°C) |
| | | | | 20 | 0.3 | 11 | 1000 | 7.1 252 | 80 0.32 | 50 | | |
| 9ADW1TS11P0M001 | 100 | 11 | | 100 | 1.08 | 61 | 2350 | 16.9 597 | 440 1.77 | 67 | | |
| | | | | 20 | 0.3 | 11 | 1000 | 7.1 252 | 80 0.32 | 50 | | |
| 9ADW1TS23P0H001 | 230 | 180 to 264 | | 100 | 1.06 | 140 | 3100 | 22.3 787 | 760 3.05 | 73 | | |
| | | | | 20 | 0.2 | 11 | 1000 | 7.1 252 | 80 0.32 | 50 | | |
| 9ADW1TS23P0M001 | 100 | 61 | 100 | 0.57 | 61 | 2350 | 16.9 597 | 440 1.77 | 67 | | | |
| | | | 20 | 0.2 | 11 | 1000 | 7.1 252 | 80 0.32 | 50 | | | |

* PWM frequency is 1 kHz. Models without ratings for 0% PWM duty cycle have zero speed at 0%. When control terminal is open, speed is the same as at 100% duty cycle.

Airflow - Static Pressure Characteristics / PWM Duty - Speed Characteristics Example

9ADW1TS11P0H001 With pulse sensor with PWM control function

PWM duty cycle

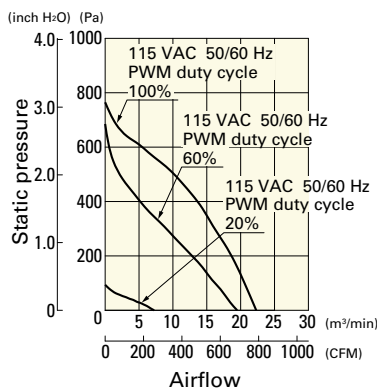

PWM duty - Speed characteristics example

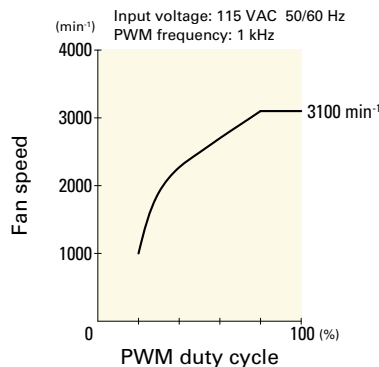

Airflow - Static Pressure Characteristics / PWM Duty - Speed Characteristics Example

9ADW1TS11P0M001 With pulse sensor with PWM control function

PWM duty cycle

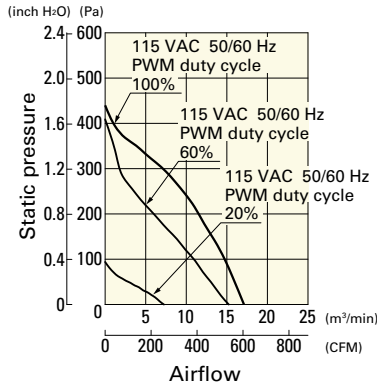

PWM duty - Speed characteristics example

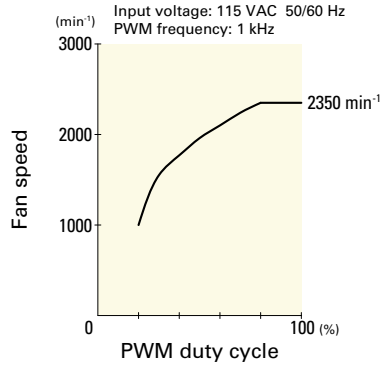

9ADW1TS23P0H001 With pulse sensor with PWM control function

PWM duty cycle

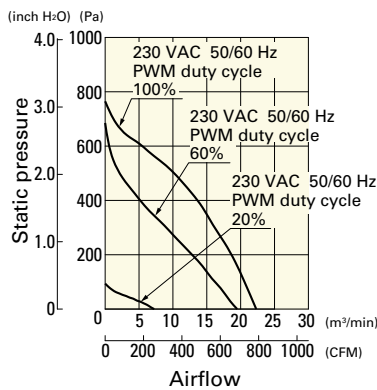

PWM duty - Speed characteristics example

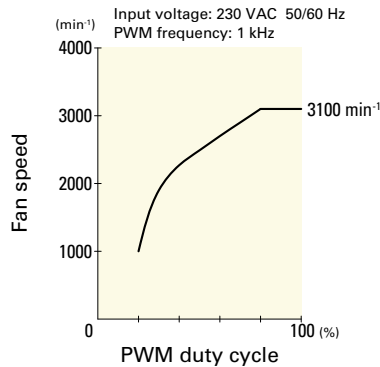

9ADW1TS23P0M001 With pulse sensor with PWM control function

PWM duty cycle

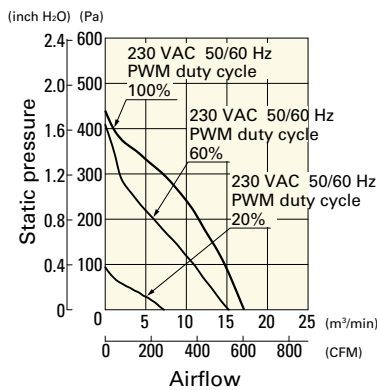

PWM duty - Speed characteristics example

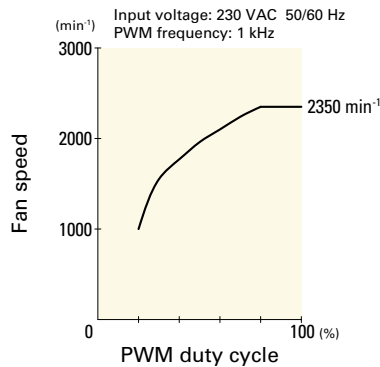

ACDC Fan φ225 mm ACDC

Connection Schematic

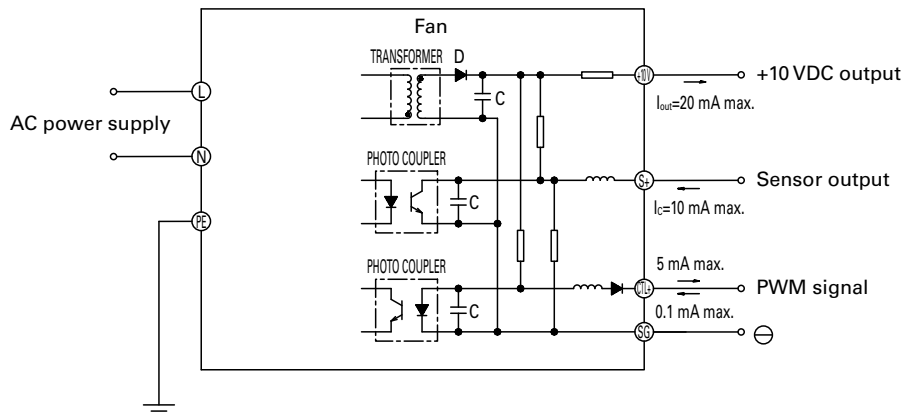

Dimensions (unit: mm)

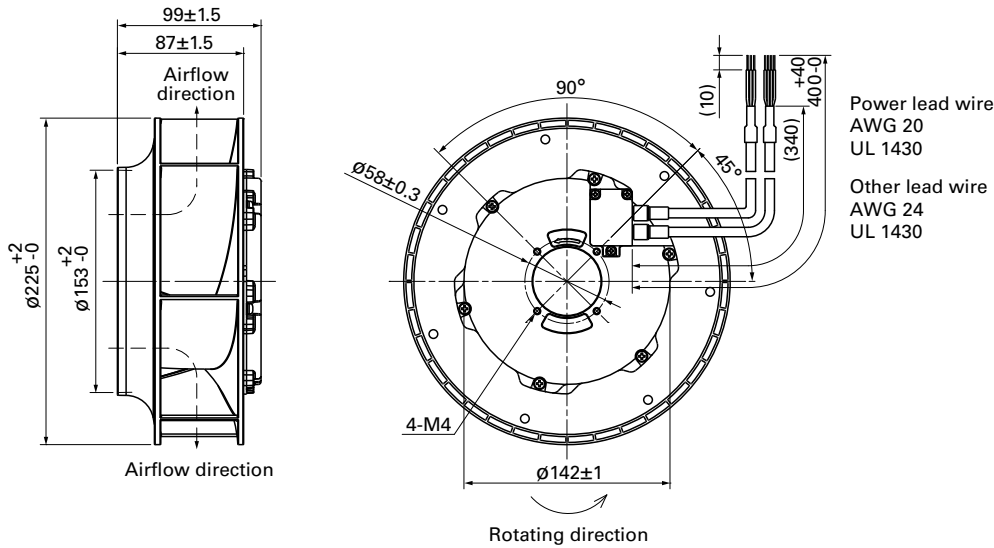

Reference Dimensions of Mounting Holes and Vent Opening (unit: mm)

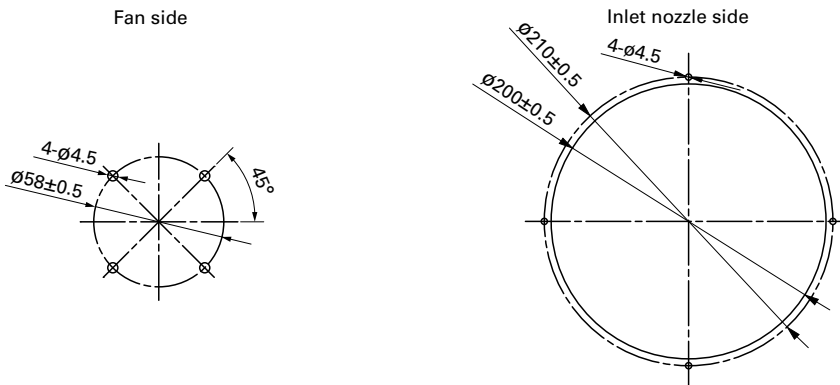

Reference Diagram for Mounting (unit: mm)

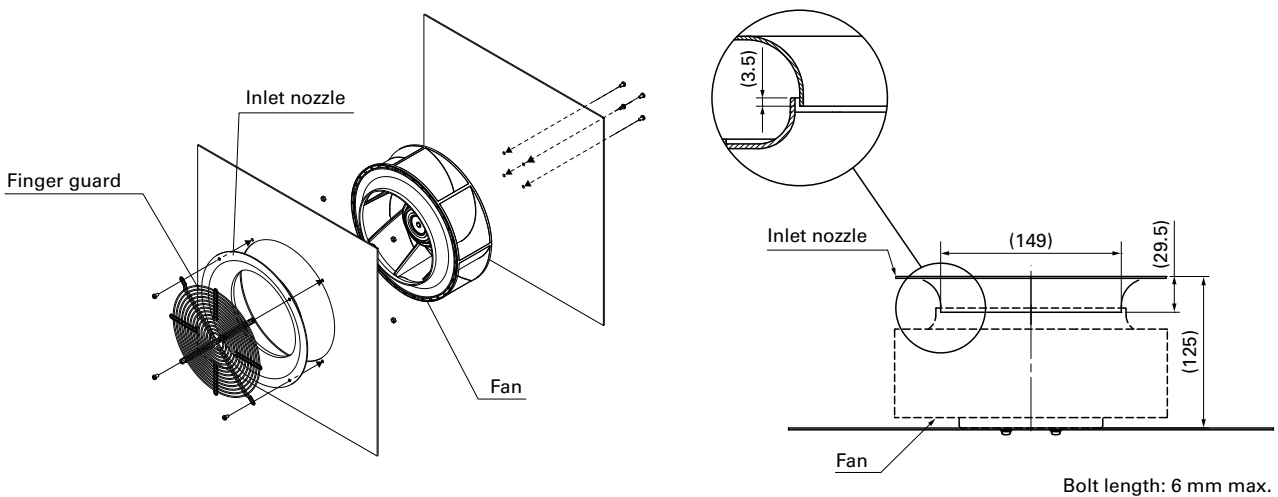

Options

Finger guards

page: p. 567

Model no.: 109-1137, 109-1137H

Inlet nozzle

page: p. 569

Model no.: 109-1134, 109-1134H