

DC Fan



# 150x150x50 mm

San Ace 150 9GV type

## General Specifications

- Material ..... Frame: Plastic (Flammability: UL 94V-0), Impeller: Plastic (Flammability: UL 94V-1)
- Expected life ..... See the table below. (L10 life: 90% survival rate for continuous operation in free air at 60°C, rated voltage)  
Expected life at 40°C is for reference only.
- Motor protection function ..... Locked rotor burnout protection, Reverse polarity protection  
For details, please refer to p. 580.
- Dielectric strength ..... 50/60 Hz, 500 VAC, for 1 minute (between lead wire conductors and frame)
- Insulation resistance ..... 10 MΩ min. at 500 VDC (between lead wire conductors and frame)
- Sound pressure level (SPL) ..... A-weighted sound pressure level (SPL) at 1 m away from the air inlet.
- Storage temperature ..... -30 to +70°C (Non-condensing)
- Lead wire ..... ⊕Red ⊖Black or Blue Sensor Yellow
- Mass ..... 450 g

## Specifications

The models listed below **have ribs and pulse sensors**. For models without ribs, append "1" to the end of model numbers.

Model no.	Rated voltage [V]	Operating voltage range [V]	Rated current [A]	Rated input [W]	Rated speed [min <sup>-1</sup> ]	Max. airflow [m <sup>3</sup> /min] [CFM]	Max. static pressure [Pa] [inchH <sub>2</sub> O]	SPL [dB (A)]	Operating temperature [°C]	Expected life [h]
9GV1512H501	12	10.2 to 13.8	2.9	34.8	3900	8.54 300	210 0.84	61	-20 to +70	40000/60°C (70000/40°C)
9GV1512M501			1.2	14.4	3000	6.35 224	132 0.53	53		
9GV1524M501	24	20.4 to 27.6	0.6	14.4	3000	6.35 224	132 0.53	53		

Note: Sensor and control options are available for selection. Refer to the table on p. 612.

## Airflow - Static Pressure Characteristics

**9GV1512H501** With pulse sensor

Operating voltage range

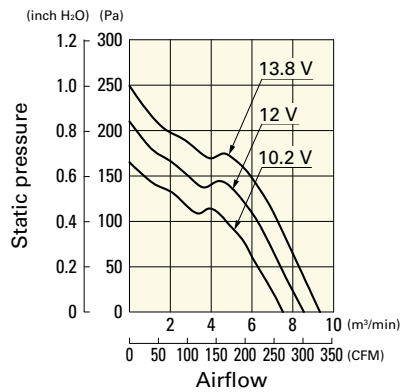

**9GV1512M501** With pulse sensor

Operating voltage range

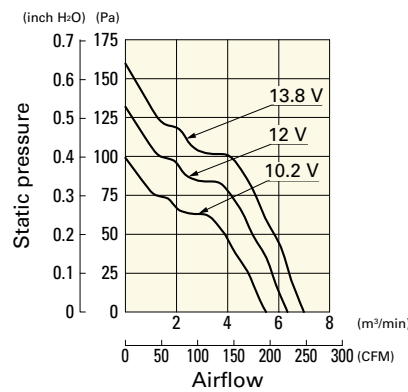

**9GV1524M501** With pulse sensor

Operating voltage range

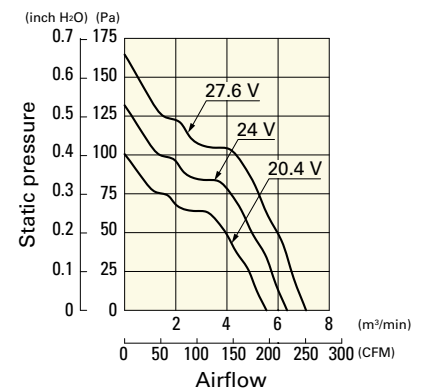

**Dimensions (unit: mm) (With ribs)**

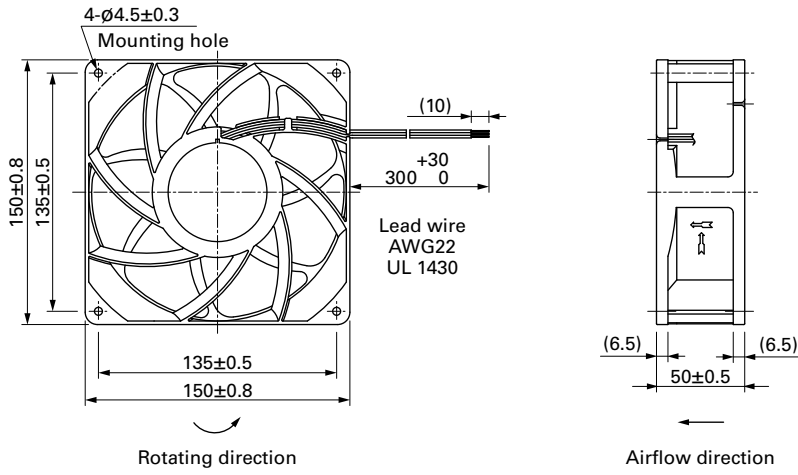

**Reference Dimensions of Mounting Holes and Vent Opening (unit: mm)**

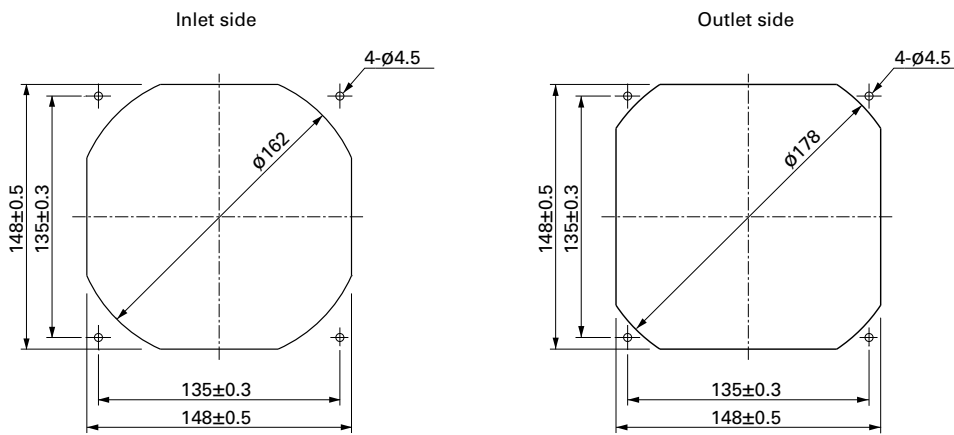

**Options**

Finger guards

page: p. 565

Model no.: 109-1051, 109-1052