



120x120x38 mm

San Ace 120AD 9AD type

General Specifications

- Material Frame: Plastic (Flammability: UL 94V-0), Impeller: Plastic (Flammability: UL 94V-1)
- Expected life See the table below. (L10 life: 90% survival rate for continuous operation in free air at 60°C, rated voltage) Expected life at 40°C is for reference only.
- Motor structure Brushless DC motor
- Motor protection function Locked rotor burnout protection For details, please refer to p. 580.
- Dielectric strength 50/60 Hz, 1500 VAC, for 1 minute (between input terminal and frame, and between sensor output and frame)
- Insulation resistance 10 MΩ min. at 500 VDC (between lead wire conductors and frame)
- Sound pressure level (SPL) A-weighted sound pressure level (SPL) at 1 m away from the air inlet.
- Storage temperature -30 to +75°C (Non-condensing)
- Mass 290 g

Do not solder wires directly to AC input terminals.

Specifications

The models listed below **have ribs and no sensors**. For models without ribs, append "1" to the end of model numbers.

Model no.	Rated voltage [V]	Operating voltage range [V]	Frequency [Hz]	Rated current [A]	Rated input [W]	Rated speed [min ⁻¹]	Max. airflow [m ³ /min] [CFM]	Max. static pressure [Pa] [inchH ₂ O]	SPL [dB (A)]	Operating temperature [°C]	Expected life [h]
▶▶ 9AD1201H12	100 to 240	90 to 264	50/60	0.08	4.4	3250	3.0 106	84 0.34	42	-20 to +75	60000/60°C (90000/40°C)

The models listed below **have ribs and low-speed sensors**. For models without ribs, append "1" to the end of model numbers.

Model no.	Rated voltage [V]	Operating voltage range [V]	Frequency [Hz]	Rated current [A]	Rated input [W]	Rated speed [min ⁻¹]	Max. airflow [m ³ /min] [CFM]	Max. static pressure [Pa] [inchH ₂ O]	SPL [dB (A)]	Operating temperature [°C]	Expected life [h]
▶▶ 9AD1201H1H	100 to 240	90 to 264	50/60	0.08	4.4	3250	3.0 106	84 0.34	42	-20 to +75	60000/60°C (90000/40°C)

Note 1: Sensor and control options are available for selection. Refer to the table on p. 621.

Note 2: The ▶▶ mark indicates Short Lead Time Service applicable models. See p. 630 for details.

Set Models

Fan, finger guard, plug cord, screws, etc. can be purchased in one package. For details, please refer to p. 631.

Order no.	Set items					
	Fan	Voltage	Low-speed sensor	Plug cord	Finger guards	Mounting screws
ST1-9AD1201H12	9AD1201H12	100 to 240 V		489-1635-L10	109-019E	M4x55 mm (4 screws)
ST1-9AD1201H1H	9AD1201H1H		○	489-1635-L10	109-019E	

Airflow - Static Pressure Characteristics

9AD1201H12, 9AD1201H1H

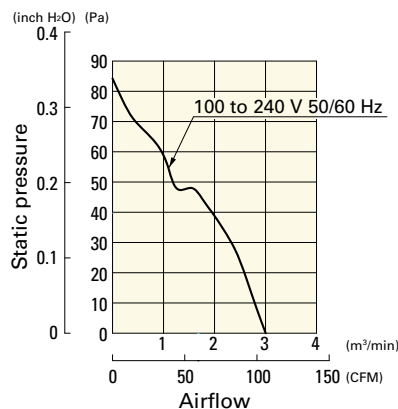

Dimensions (unit: mm) (With ribs)

without Sensor

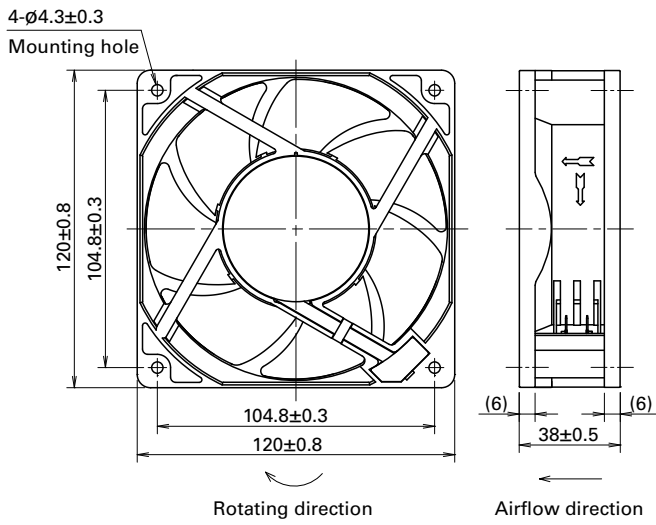

with Low-speed sensor

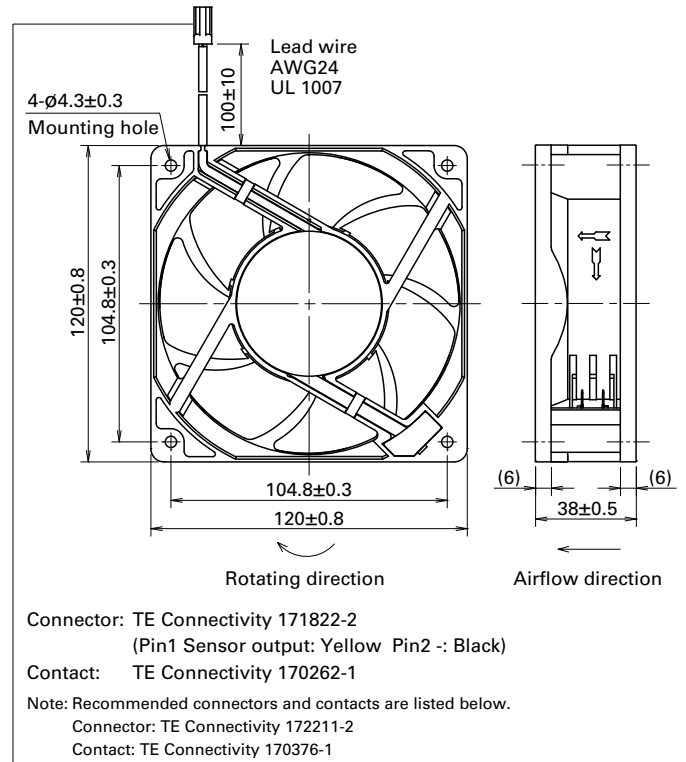

Reference Dimensions of Mounting Holes and Vent Opening (unit: mm)

ACDC Fan 120 mm sq.

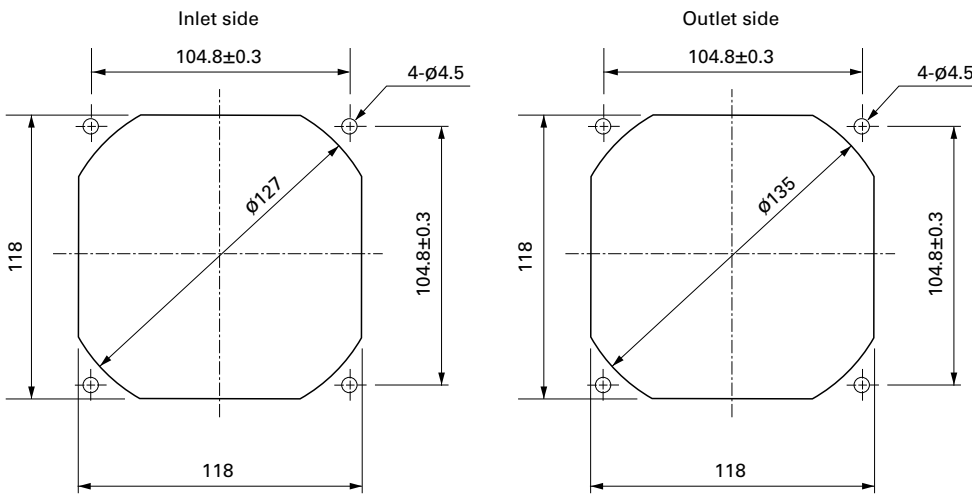

Connection Schematic

without Sensor

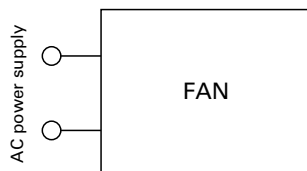

with Low-speed sensor

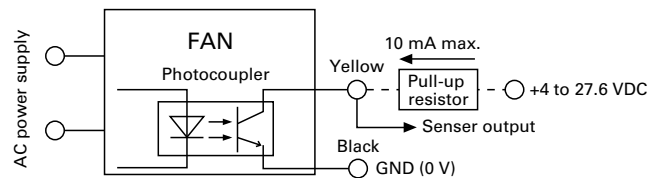

Specifications for Low-speed Sensors

Model No.: 9AD1201H1H

Output circuit: Open collector

$V_{CE} = +27.6$ VDC max.
 $I_C = 10$ mA max. [$V_{CE(SAT)} = 1.0$ V max.]

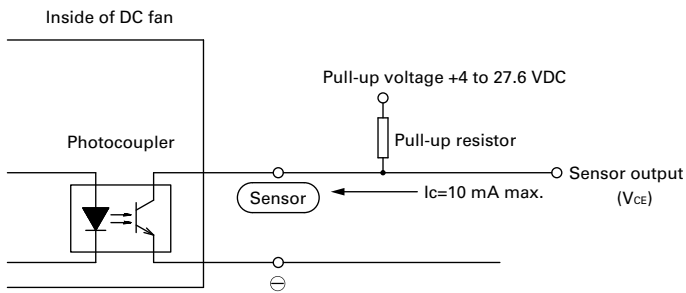

Sensor scheme

Example 1: when steady running

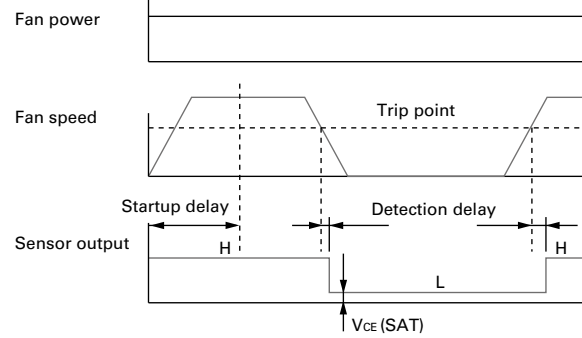

Example 2: when the rotor is locked when the fan motor is turned on and released after the start-up delay time.

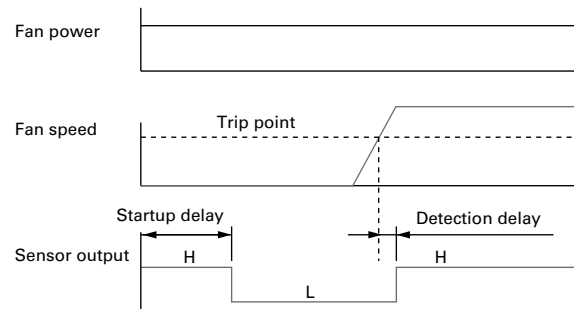

Startup delay: 18 ± 3 s
 Detection delay: 3 s max.
 Trip point: 1700 min^{-1}

Options

Finger guards page: p. 565

Model no.: 109-019E, 109-019K, 109-019C, 109-019H

Resin finger guards page: p. 571

Model no.: 109-1000G

Resin filter kits page: p. 572

Model no.: 109-1000F13 (13PPI), 109-1000F20 (20PPI),
 109-1000F30 (30PPI), 109-1000F40 (40PPI)

Plug cord page: p. 575

Model no.: 489-1635-L10, 489-1635-L21

Sensor extension wiring harness page: p. 575

Model no.: 489-1636

ACDC Fan 120 mm sq.

Features of the San Ace 120AD 9AD type ACDC Fan

Low power consumption **Long life** **Wide voltage range** (Compared with our existing AC fan with equal size.)

With AC input, the same level of energy saving and long life as a DC fan can be achieved.
 The maintenance effort can be reduced too.

Power consumption comparison

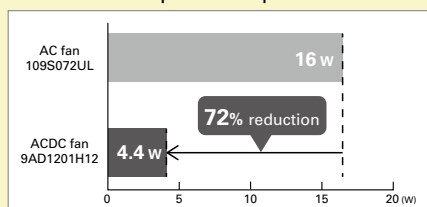

Expected life comparison

