



# ∅106 mm

1.8°/step RoHS

Unipolar, lead type  
Bipolar, lead type

### Custom options

- Hollow shaft Custom shaft
- Brake

Note: Customization feasibility depends on the model number and quantity. Contact us for details.

### Unipolar, lead type

Model no.		Holding torque at 2-phase excitation	Rated current	Winding resistance	Winding inductance	Rotor inertia	Mass	Motor length (L)
Single shaft	Dual shaft	N·m or more	A/phase	Ω/phase	mH/phase	×10 <sup>-4</sup> kg·m <sup>2</sup>	kg	mm
<b>103H89222-0941</b>	<b>103H89222-0911</b>	10.8	4	0.98	6.3	14.6	7.5	163.3
<b>103H89223-0941</b>	<b>103H89223-0911</b>	15.5	4	1.4	9.7	22	10.5	221.3

### Bipolar, lead type

Model no.		Holding torque at 2-phase excitation	Rated current	Winding resistance	Winding inductance	Rotor inertia	Mass	Motor length (L)
Single shaft	Dual shaft	N·m or more	A/phase	Ω/phase	mH/phase	×10 <sup>-4</sup> kg·m <sup>2</sup>	kg	mm
<b>103H89222-5241</b>	<b>103H89222-5211</b>	13.2	6	0.45	5.4	14.6	7.5	163.3
<b>103H89223-5241</b>	<b>103H89223-5211</b>	19	6	0.63	8	22	10.5	221.3

## Characteristics

### 103H89222-0941 103H89222-0911

Constant current circuit  
Input voltage: 100 VAC  
Winding current:  
4 A/phase  
At 2-phase excitation (full step)  
Pull-out torque:  
 $J_L = 44 \times 10^{-4} \text{kg}\cdot\text{m}^2$   
(with rubber coupling used)  
 $f_s$ : Maximum starting pulse rate with no load

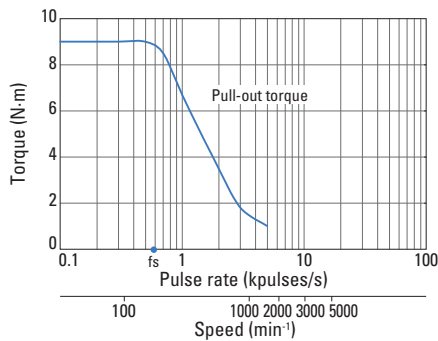

### 103H89223-0941 103H89223-0911

Constant current circuit  
Input voltage: 100 VAC  
Winding current:  
4 A/phase  
At 2-phase excitation (full step)  
Pull-out torque:  
 $J_L = 44 \times 10^{-4} \text{kg}\cdot\text{m}^2$   
(with rubber coupling used)  
 $f_s$ : Maximum starting pulse rate with no load

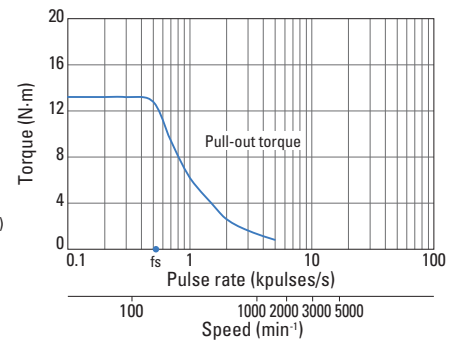

### 103H89222-5241 103H89222-5211

Constant current circuit  
Input voltage: 100 VAC  
Winding current:  
6 A/phase  
At 2-phase excitation (full step)  
Pull-out torque:  
 $J_L = 44 \times 10^{-4} \text{kg}\cdot\text{m}^2$   
(with rubber coupling used)  
 $f_s$ : Maximum starting pulse rate with no load

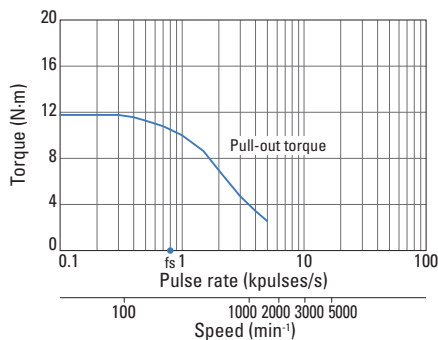

### 103H89223-5241 103H89223-5211

Constant current circuit  
Input voltage: 100 VAC  
Winding current:  
6 A/phase  
At 2-phase excitation (full step)  
Pull-out torque:  
 $J_L = 44 \times 10^{-4} \text{kg}\cdot\text{m}^2$   
(with rubber coupling used)  
 $f_s$ : Maximum starting pulse rate with no load

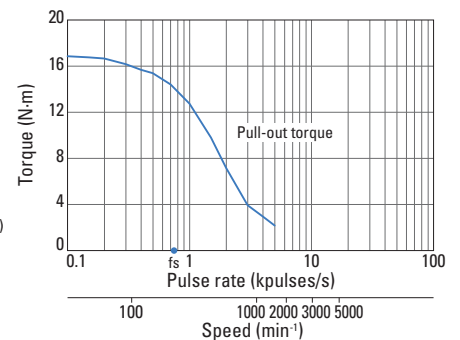

## Dimensions (Unit: mm)

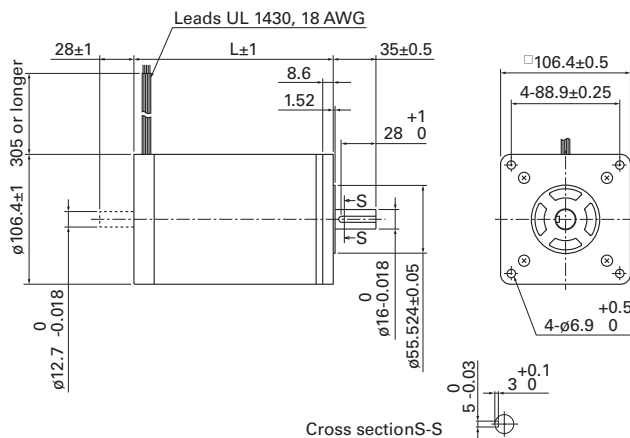

## Internal winding

### Unipolar

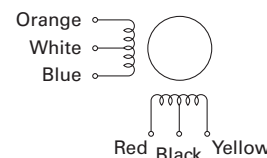

### Bipolar

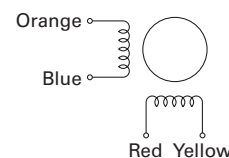

## Compatible drivers

A driver is to be provided by the customer.