



# Ø 100x25 mm

San Ace 100W 9W1TM<sub>type</sub> US

## General Specifications

- Material ..... Motor case: Aluminum (Black coating), Impeller: Plastic (Flammability: UL 94V-0)
- Expected life ..... See the table below. (L10 life: 90% survival rate for continuous operation in indoor free air at 60°C, rated voltage) Expected life at 40°C is for reference only.
- Motor protection function ..... Locked rotor burnout protection, Reverse polarity protection  
For details, please refer to p. 580.
- Dielectric strength ..... 50/60 Hz, 500 VAC, for 1 minute (between lead wire conductors and motor case)
- Insulation resistance ..... 10 MΩ min. at 500 VDC (between lead wire conductors and motor case)
- Sound pressure level (SPL) ..... A-weighted sound pressure level (SPL) at 1 m away from the air inlet.
- Storage temperature ..... -30 to +70°C (Non-condensing)
- Lead wire ..... ⊕Red ⊖Black  Sensor Yellow  Control Brown
- Mass ..... 160 g
- Ingress protection ..... IP54

## Specifications When the optional inlet nozzle (109-1080) is mounted.

The models listed below **have pulse sensors with PWM control function.**

Model no.	Rated voltage [V]	Operating voltage range [V]	PWM duty cycle [%]	Rated current [A]	Rated input [W]	Rated speed [min <sup>-1</sup> ]	Max. airflow [m <sup>3</sup> /min] [CFM]	Max. static pressure [Pa] [inchH <sub>2</sub> O]	SPL [dB (A)]	Operating temperature [°C]	Expected life [h]
9W1TM48P4G01	48	36 to 60	100	0.36	17.28	7400	2.03 71.7	708 2.84	65	-20 to +70	40000/60°C (70000/40°C)
9W1TM48P4H01			100	0.22	10.56	6400	1.77 62.5	560 2.25	60		
			0	0.04	1.92	2000	0.51 18.0	48 0.19	34		

\* PWM frequency is 25 kHz. Models without ratings for 0% PWM duty cycle have zero speed at 0%. When control terminal is open, speed is the same as at 100% duty cycle.

Note: Max input of 9W1TM48P4G01: 22 W, 9W1TM48P4H01: 14 W at rated voltage.

## Airflow - Static Pressure Characteristics / PWM Duty - Speed Characteristics Example

### 9W1TM48P4G01 With pulse sensor with PWM control function

PWM duty cycle

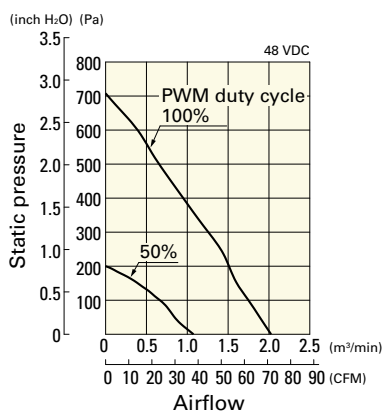

Operating voltage range

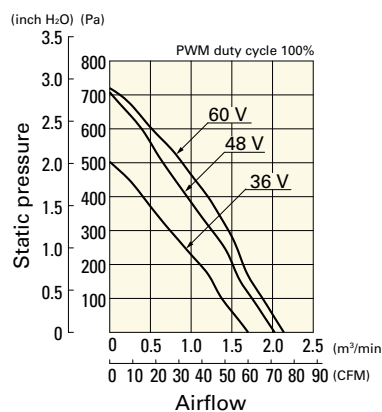

PWM duty - Speed characteristics example

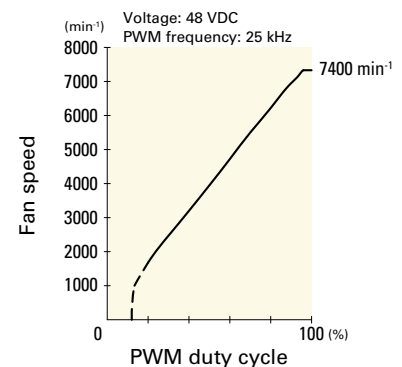

## Airflow - Static Pressure Characteristics / PWM Duty - Speed Characteristics Example

**9W1TM48P4H01** With pulse sensor with PWM control function

PWM duty cycle

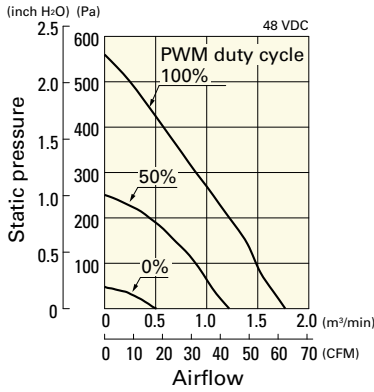

Operating voltage range

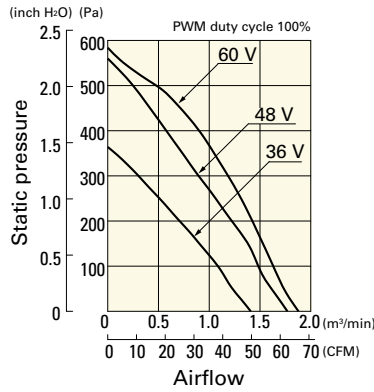

PWM duty - Speed characteristics example

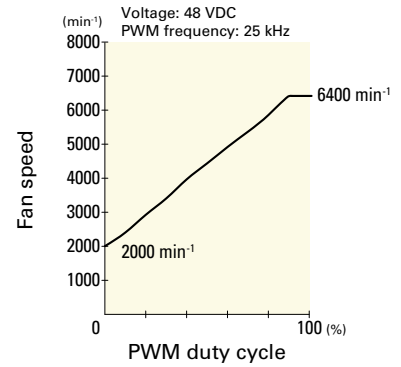

## Dimensions (unit: mm)

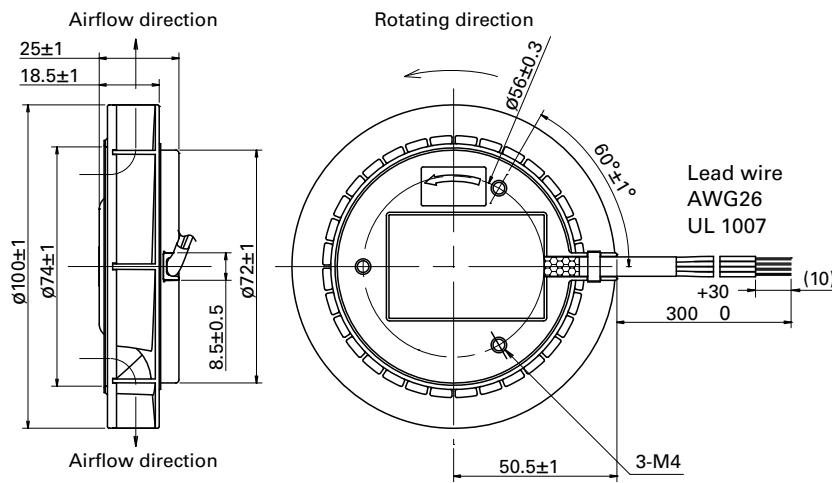

## Reference Dimensions of Mounting Holes and Vent Opening (unit: mm)

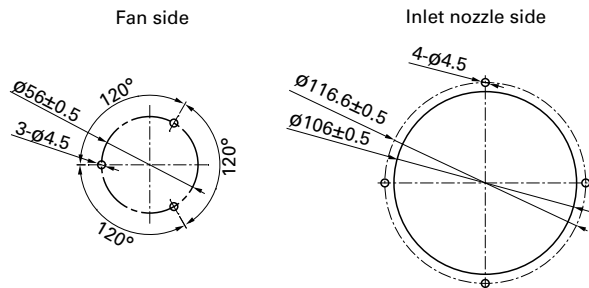

## Reference Diagram for Mounting (unit: mm)

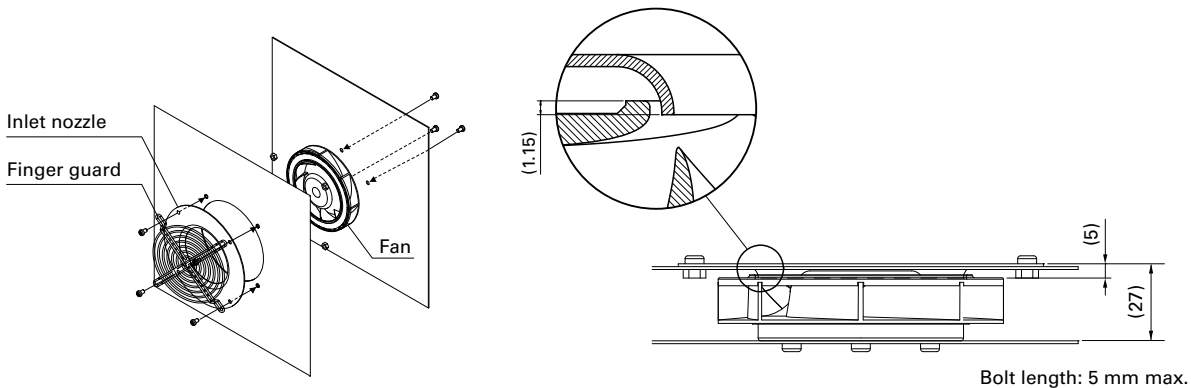

## Options

---

Finger guards

page: p. 564

Model no.: 109-099E, 109-099H

Inlet nozzle

page: p. 569

Model no.: 109-1080, 109-1080H

**DC**

Splash Proof Centrifugal Fan ø100 mm